

GTC-600

Crane capacity **4-section boom**
66 US ton (60t) 118.1 ft (38.0m)

Jib options
8.2 ft (2.5m) heavy lift jib
33.1 ft (10.1m) / 58.1 ft (17.7m) bi-fold jib

Maximum lifting height
125.3 feet (38.2 m) (boom)
182.1 ft (55.5 m) (jib)

OPTI-WIDTH™
OPTIMAL lifting performance at any
track WIDTH



MODEL: GTC-600

CRANE CAPACITY	66 ton at 10 feet (60t at 3.0m)
BOOM	4-section full power telescoping boom with 2 extension modes.
Retracted Length:	37.7 feet (11.5m)
Extended Length:	118.1 feet (38.0 m)
Max. Lifting Height:	125.3 feet (38.2 m)
Extension Time:	125 s
Elevating Angles:	-1.5° to 80.0°
Elevating Time:	89 s
Heavy lift jib	• Total Length: 8.2 ft (2.5 m) • Offset Angles: 3.5° & 30° • Max. Lifting Height: 126.6 ft (38.6 m)
Main Jib	• Total Length: 33.1 ft (10.1m) • Offset Angles: 3.5°, 25° & 45° • Max. Lifting Height: 157.9 feet (48.1m)
Fly Jib	• Total Length: 58.1 ft (17.7 m) • Offset Angles: 3.5°, 25° & 45° • Max. Lifting Height: 182.1 ft (55.5 m)
Gross Vehicle Mass	140,086 lb (63,387 kg)
Counterweight	• Upper = 30,000 lb (13,608 kg) • Carbody = 13,226 lb (6,000 kg)
Travel Speed	0.8 mph (1.3 km/hr)/ 2.5 mph (4.0 km/hr)
Gradeability	78%
Swing Speed	2.4 RPM
Tail Swing Radius	14' - 5" (4.39m)
House Lock Systems	• 4-position house lock (boom over front, rear or either side). Actuated from the operator's cab. • Optional 360 degree house lock. Actuated from the operator's cab.
Swing Park Brake	Spring applied failsafe brake with hydraulic release that is controlled from the operators cab
Swing Service Brake	Hydraulically applied, controlled through foot actuated pedal
Winches	Planetary geared two-speed winch includes a hydraulic motor, multi-disc internal brake and counterbalance valve. Drum rotation indicator, cable follower and grooved drum is included
Main Winch	• Rope Diameter and Length: 3/4 in x 650 ft (19mm x 198m) • Single line pull: 19,830 lb (88.2 kN) (first layer) • Single line speed: 368 ft/min (112.2 m/min) (4th layer)
Auxiliary Winch	• Rope Diameter and Length: 3/4 in x 410 ft (19mm x 125m) • Single line pull: 19,830 lb (88.2 kN) (first layer) • Single line speed: 368ft/min (112.2 m/min) (4th layer)

Load Moment Indicator	<ul style="list-style-type: none"> TADANO AML-C Rated Capacity Limiter and Anti-Two Block system OPTI-WIDTH™ - OPTIMAL lifting performance at any track WIDTH Control function shutdown. Audible and visual warnings LCD screen provides a continuous display of working boom length, boom angle, working load radius, tip height, swing position, parts-of-line (operator set), machine track configuration, relative load moment, maximum permissible load and actual load. Operator configurable working range limits with automatic soft stop.
Telematics	Machine data logging and monitoring system with HELLO-NET via Internet.
Diesel Engine	<ul style="list-style-type: none"> Make/ Model: Cummins QSB6.7 Type: 6 Cylinder, Water cooled, 4 Cycle Aspiration: Turbocharged and Aftercooled Max. Output: 310 hp (231 kW) @ 2200 RPM Max Torque: 770 lb-ft (1,044 Nm) @ 1500 RPM Piston Disp: 6.7 L Emission Cert: U.S. EPA Tier 4f, Euromot Stage IV Alternator: 70 amp
Electrical System	24 VDC
Fuel Capacity	85 gallon (321 liter)
Hydraulic System	<ul style="list-style-type: none"> Hydraulic Pumps: Two high pressure, variable axial piston pumps with load sense and power limiting control for crane functions. One axial piston pump for swing function. One gear pump for cooling loop. Directional Valves: Multiple pressure and flow compensated valves with integrated relief valves controlled by electrical signals. Pump output: 154 gpm (582 l/min) @ 2200 RPM engine speed. 5,000 psi (345 bar) maximum pressure Reservoir 227 gallon (861 liter) capacity, spin-on filler breather, sight gauge, cleanout and sump drain. Filtration: Three 5 micron, full-flow tank-mounted return filters with electrical clogging indicator. 3 micron pilot oil in-line pressure filter. Diagnostic Ports: Provided for system, load sense and pilot pressure.
Optional Equipment	<ul style="list-style-type: none"> Track Shoes: 31.5 in (800mm) steel flat shoe. Work Platform: Model WP750 - 36 in x 72 in (0.9m x 1.8m), all steel, welded, two-person platform with maximum capacity of 750 lbs (340 kg). Cold Weather Packages: Cold weather options are available for operation to -40°C (Consult factory for application support). Controlled Free Fall Hoists: Winches are available in controlled free fall configurations. Hydraulic tool Circuit: Provides 5 gpm (23 l/min) and 10 gpm (45 l/min) at 2,500 PSI (176 bar) through a 50 foot (15.2m) twin hose reel with quick disconnect fittings to operate open center tools. Radio control package. Auger Package: Hydraulic auger boom package includes auger motor, hoses, fasteners, and stowage bracket assembly mounted to the 2nd stage section of boom for variable radius drilling.

WORKING RANGE

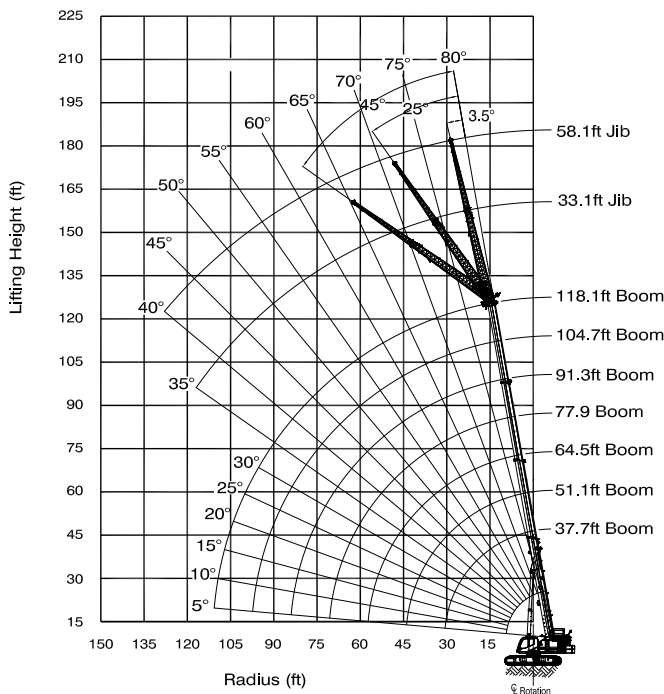

DIMENSIONS

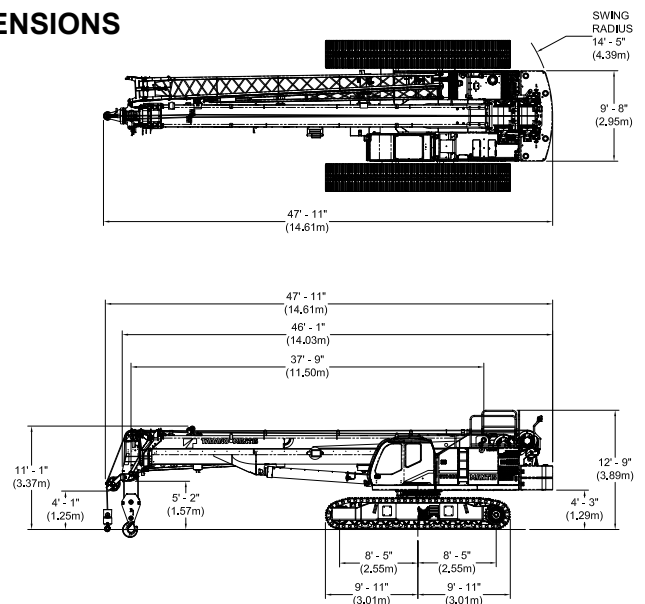

Specifications are subject to change without prior notice.



Lifting your dreams

TADANO MANTIS Corporation

1705 Columbia Avenue Franklin, Tennessee 37064, U.S.A.
Phone: +1-800-272-3325 Fax: +1-615-790-6803
<http://www.mantiscranes.com/> E-mail: sales@mantiscranes.com

TADANO LTD. (International Division)

4-12, Kamezawa 2-chome, Sumida-ku Tokyo 130-0014, Japan
Phone: 81-3-3621-7750 Fax: 81-3-3621-7785
<http://www.tadano.com> E-mail: info@tadano.com

GTC-600

66 Ton Telescopic Boom Crawler Crane

SPECIFICATION SHEET NO. TMC-DI-734-14 02/17

GENERAL DATA

CRANE CAPACITY	66 ton at 10 feet (60t at 3.0m)
BOOM	4-section, 37' 8" – 118' 1" (11.5 m – 38.0 m)
DIMENSION	
Overall Length	46' 1" (14.08 m)
Overall Width (tracks extended)	16' 2" (4.92 m)
Overall Width (tracks retracted)	10' 9" (3.27 m)
Overall Width (tracks removed)	9' 8" (2.95 m)
Overall Height (working)	12' 9" (3.89 m)
MASS	
Gross Vehicle Mass (Standard Equipment Package)	140,086 lb (63,387 kg)
Maximum Counterweight	Upper = 30,000 lb (13,608 kg) Carbody = 13,226 lb (6,000 kg)
PERFORMANCE	
Travel Speed	0.8 mph (1.3 km/hr)/ 2.5 mph (4.0 km/hr)
Gradeability	78%

CRANE SPECIFICATION

MODEL	CAPACITY
GTC-600	66 ton at 10 feet (60t at 3.0m)

BOOM

4-section full power telescoping boom with 2 extension modes. System consists of three double acting hydraulic cylinders with load holding valves and extension and retraction cables.

- Retracted Length: 37' 8" (11.5m)
- Extended Length: 118' 1" (38.0 m)
- Elevating Angles: -1.5° to 80.0°
- Max Lifting Height: 125' 3" (38.2m)
- Boom Head: Six, 19.5 inch (495 mm) diameter cast nylon main sheaves on heavy-duty roller bearings. Two, 17.5" (445mm) diameter cast nylon lead in sheaves on heavy-duty roller bearings). Designed for quick reeving of head and load block.

AUXILIARY BOOM HEAD

Quick reeve, single 17.5 inch (445 mm) diameter high-strength, cast nylon sheave mounted on a heavy-duty roller bearing. Allows single part reeving.

COUNTERWEIGHT

- 4 piece counterweight design. Two upper counterweight configurations
- "A" Configuration = 30,000lb (13,608 kg)
 - "B" Configuration = 15,000lb (6,804 kg)
 - Two carbody counterweights, 6,613lb (3,000kg) each

WINCHES

Planetary geared two-speed winch includes a hydraulic motor, multi-disc internal brake and counterbalance valve. Drum rotation indicator is included (complete winch performance specs on Page 3)

- Main Winch
 - o Rope Diameter and Length: 3/4 in x 650 ft (19mm x 198m)
 - o Single line pull: 19,830 lb (88.2 kN)(first layer)
 - o Single line speed: 368 ft/min (112.2 m/min)(4th layer)
- Auxiliary Winch
 - o Rope Diameter and Length: 3/4 in x 410 ft (19mm x 125m)
 - o Single line pull: 19,830 lb (88.2 kN)(first layer)
 - o Single line speed: 368 ft/min (112.2 m/min)(4th layer)

TRAVEL

Each side frame contains a pilot controlled, two-speed track drive with hydraulic axial piston motor and parking brake. Travel system provides skid steering and counter rotation.

- Travel speed - Low: 0.8 mph (1.3 km/hr) High: 2.5 mph (4.0 km/hr)
- Gradeability (unladen): 78%
- Unladen Ground Pressure: 9.8 psi (0.67 kg/cm²)

SWING

Gear motor driving a planetary gear reducer with a shaft mounted pinion, external gear shear ball slew bearing bolted to the superstructure and the carbody allows the superstructure to rotate 360°

- Swing Speed: 0 - 2.4 rpm
- Swing Parking Brake: Spring applied failsafe brake with hydraulic release that is controlled from the operators cab
- Swing Service Brake: Hydraulically applied, controlled through foot actuated pedal
- House Lock System
 - o 4-position house lock (boom over front, rear or either side). Actuated from the operator's cab.

LOAD MOMENT INDICATOR

TADANO AML-C Rated Capacity Limiter and Anti-Two Block system

- OPTI-WIDTH™ - OPTIMAL lifting performance at any track WIDTH
- Control function shutdown. Audible and visual warnings
- LCD screen provides a continuous display of working boom length, boom angle, working load radius, tip height, swing position, parts-of-line (operator set), machine track configuration, relative load moment, maximum permissible load and actual load.
- Anti-two block weight allows quick reeving of hook block
- Operator configurable working range limits with automatic soft stop.

FRAME

The frame is an all-steel, welded structure, precision machined to accept attachment of the boom and swing components.

OPERATORS CAB

Fully-enclosed, air conditioned all-steel modular cab with lockable sliding door, acoustical lining, anti-slip floor and tinted safety glass.

- Cab tilts 20°.
- Rear view, winch view and right side view video cameras
- Three remote control work lights.
- Vent window in the rear of the cab.
- Grab bars and steps are located for easy access to the cab.
- Defroster, heater, circulating fan
- 2-speed windshield wiper, top glass wiper
- Six-way adjustable fabric seat with headrest, seat belt
- Dome light
- Dry-chemical fire extinguisher
- Four-way electronic armrest mounted joysticks control swing, main winch, auxiliary winch, boom hoist and boom extend. Foot pedals control the travel and swing service brake functions. Swing brake pedal is hydraulic.
- Selectable modes for Fine Control and Travel. Travel function can be operated by foot pedals or joystick.
- Seat termination switch immediately disable all hydraulic functions as the operator rises from the seat. Functions can also be disabled by switch on console.
- Dash instrumentation: tachometer, hour meter, fuel gauge, and DEF level gauge. Indicators are provided for crane level, swing position, load moment, drum rotation, air filter restriction, engine oil temperature and pressure, hydraulic oil temperature and level, and hydraulic and air filter restriction, and low voltage.

ENGINE

- Make/ Model: Cummins QSB6.7
- Type: 6 Cylinder, Water cooled, 4 Cycle
- Aspiration: Turbocharged and Aftercooled
- Max. Output: 310 hp (231 kW) @ 2200 RPM
- Max Torque: 770 Lb-ft (1,044 Nm) @ 1500 RPM
- Piston Disp: 6.7 L
- Emission Cert: U.S. EPA Tier 4f, Euromot Stage IV
- Alternator: 70 amp

ELECTRICAL SYSTEM

24 VDC

FUEL SYSTEM

- Capacity: 85 gallon (321 liter)
- Filtration: Inline fuel/water separator and engine mounted fuel filter

SIDE FRAMES

Two welded steel side frames are paired with a track group. The side frames extend and retract hydraulically and are controlled from the cab.

- Track Rollers: Two top and thirteen bottom sealed rollers on each track frame Idler: Oil filled, self lubricating with nitrogen type tensioner
- Track Shoes: 35.4 inch (900 mm), 3-bar semi grouser

HYDRAULIC SYSTEM

- Hydraulic Pumps: Two high pressure, variable axial piston pumps with load sense and power limiting control for crane functions. One axial piston pump for swing function. One gear pump for cooling loop.
- Directional Valves: Multiple pressure and flow compensated valves with integrated relief valves controlled by electrical signals.
- Pump output: 154 gpm (582 l/min) @ 2200 RPM engine speed. 5,000 psi (345 bar) maximum pressure
- Reservoir: 227 gallon (861 liter) capacity, spin-on filler/ breather, sight gauge, cleanout, and sump drain.
- Filtration: Three 5 micron, full flow tank mounted return filters with electrical clogging indicator. 3 micron pilot oil in-line pressure filter
- Diagnostic Ports: Provided for system, load sense, and pilot pressure

BI-FOLD JIB

o Main jib

- Total Length: 33.1 ft (10.1m)
- Offset Angles: 3.5°, 25° & 45°
- Max. Lifting Height: 157.9 ft (48.1 m)

o Fly jib

- Total Length: 58.1ft (17.7m)
- Offset Angles: 3.5°, 25° & 45°
- Max. Lifting Height: 182.1 ft (55.5 m)

OPTIONAL EQUIPMENT

- Heavy lift jib
 - Total Length: 8.2ft (2.5 m)
 - Offset Angles: 3.5° & 30°
 - Max. Lifting Height: 126.6 ft (38.6m)
- Hook blocks
 - o 66 ton (60t) quick reeve hook block – Six, 19.5 in (495mm) steel sheaves, swivel hook and safety latch
 - o 55 ton (50t) quick reeve hook block – three, 19.5 in (495mm) steel sheaves, swivel hook and safety latch
 - o 22 ton (20t) quick reeve hook block – one, 19.5 in(495mm) steel sheave, swivel hook and safety latch
- Overhaul ball – 8.8 ton (8t) with swivel hook & safety latch
- 360 degree house lock. Actuated from the operator's cab.
- Track Shoes: 31.5 inch (800 mm) steel flat shoe.
- Auger: Hydraulic auger boom package includes auger motor, hoses, fasteners, and stowage bracket assembly mounted to the 2nd stage section of boom for variable radius drilling.
- Tool Circuit: Provides 5 gpm (23 l/min) and 10 gpm (45 l/min) at 2,500 PSI (176 bar) through a 50 foot (15.2m) twin hose reel with quick disconnect fittings to operate open center tools.
- High Flow Tool Circuit: Provides 45 gpm (170 l/min) at 4800 PSI (330 bar)
- Carbody Jack System: Includes carbody mounted jacks, valves, electric control pendant, and auto-level raise system.
- Controlled Free Fall Hoists: Winches are available in controlled free fall configurations.
- Cold Weather Packages: Cold weather options are available for operation to -40°C (Consult factory for application support)
- Work Platform: Model WP750 – 36 in x 72 in (0.9m x 1.8m), all steel, welded, two person platform with maximum capacity of 750 lbs (340 kg).
- Radio control package.
- Anemometer: boom mounted wireless anemometer with cab display.
- Central lubrication system.

MAIN WINCH AND AUXILIARY WINCH PERFORMANCE

Wire Rope: 19 mm diameter rotation resistant. Line pulls are not based on wire rope strength.

Rope Layer	Max Line Pull (lb)	High Line Speed (ft/min)	Normal Line Speed (ft/min)	Pitch Dia (in)	Layer (ft)	Total (ft)
1	19,828	290.3	172.5	15.0	112.2	112.2
2	17,962	316.2	187.9	16.6	122.3	234.5
3	16,411	342.1	203.7	18.2	132.2	366.7
4	15,107	368.0	219.1	19.7	142.4	509.1
5	14,006	394.3	234.5	21.3	152.2	661.2
6	13,039	420.2	249.9	22.9	162.4	823.6

MACHINE WEIGHTS

	LB	KG
Standard Crane with 4 section - 118.1' boom, full counterweight, 2 winches with wire rope, bi-fold jib, auxiliary nose sheave and 35.4" 3-bar semi grouser track shoes,	140,086	63,387
Standard Crane with 4 section - 118.1' boom, 2 winches with wire rope, auxiliary nose sheave and 35.4" 3-bar semi grouser track shoes, (Counterweight removed)	96,860	43,828
OPTIONAL EQUIPMENT	LB	KG
Heavy Lift Jib - 8.2 ft (2.5m)	972	440
Jib Base - 33.1 ft (10.1 m)	2,030	919
Jib Tip - 24.67 ft (7.5m)	750	339
Auxiliary Nose Sheave	105	48
66 ton (60t) hook block - six sheave	1,200	543
55 ton (50t) hook block - three sheave	1,021	462
22 ton (20t) hook block - one sheave	655	296
8.8 ton (8t) Overhaul Ball	295	133

GTC-600

66 Ton Telescopic Boom Crawler Crane

SPECIFICATION SHEET NO. TMC-DI-734-14 02/17

DIMENSIONS

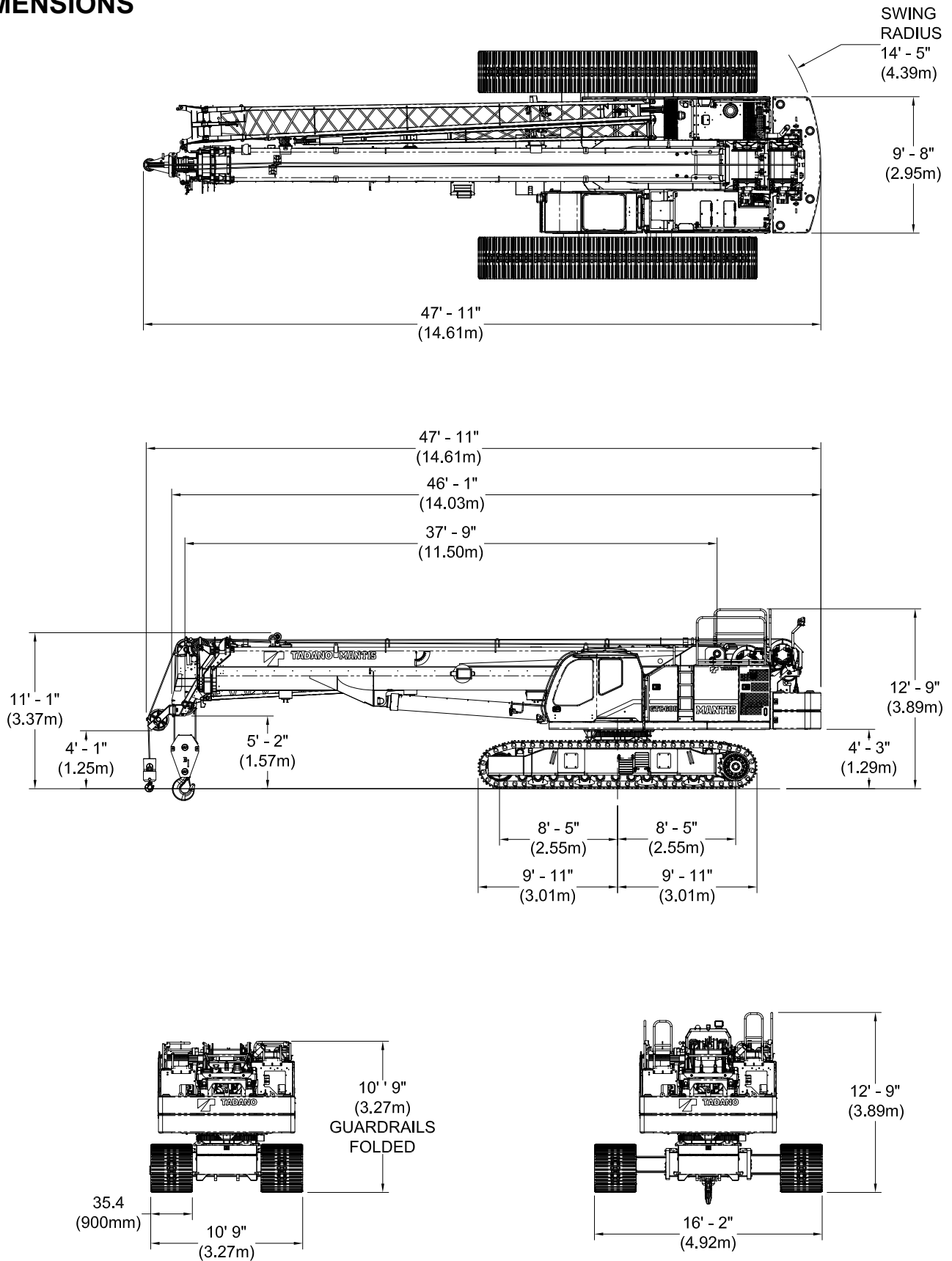

TRANSPORT DIMENSIONS

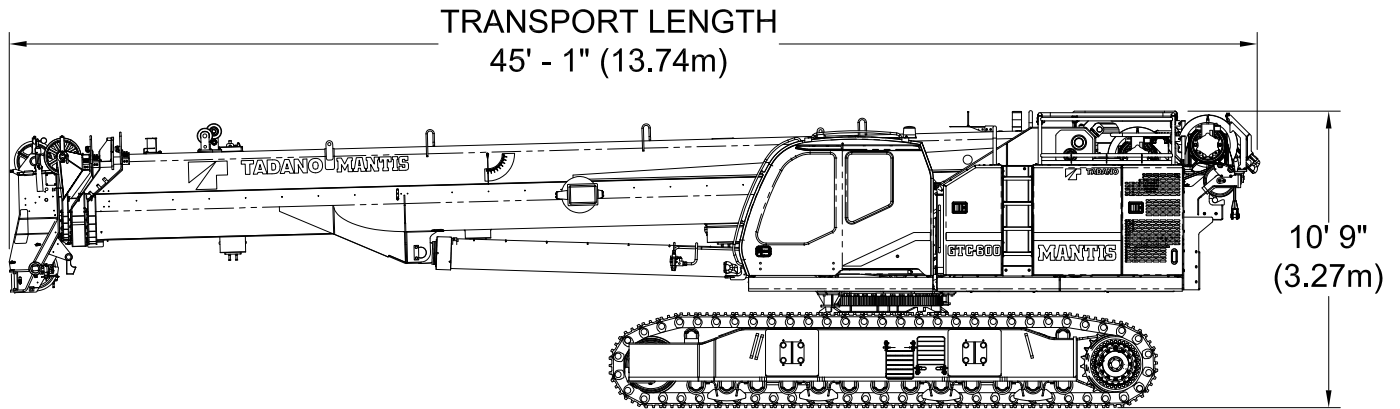

TRANSPORT PLAN

Item	Weight		Dims (L x W x H)	Trailer	
	Lbs	Kg		1	2
Crane (with 2 winches, Boom, wire rope, aux nose sheave)	92,390	41,907	45' 1" x 10' 9" x 10' 9"	X	
Counterweight A	15,000	6,804	9' 8" x 3' 8" x 3' 5"		X
Counterweight B - 1 piece	15,000	6,804	9' 8" x 1' 6" x 3' 5"		X
Counterweight - Carbody - 1 piece	6,613	3,000	4' 3" x 3' 2" x 2' 5"		X
Counterweight - Carbody - 1 piece	6,613	3,000	4' 3" x 4' 9" x 2' 6"		X
Jib base section	2,030	921	34' 8" x 4' 10" x 3' 0"	X	
Jib point	750	340	25' 9" x 2' 5" x 2' 5"	X	
Hook Block - 60 metric ton	1,200	544	5' 2" x 2' 0" x 1' 6"	X	
Headache Ball - 8 ton	440	200	2' 5" x 0' 11" x 0' 11"	X	
Miscellaneous Items (Crate)	50	23	4' 0" x 3' 0" x 3' 0"	X	
Total Net Weight on Trailer (Lbs)				96860	43226

TRANSPORT DIMENSIONS

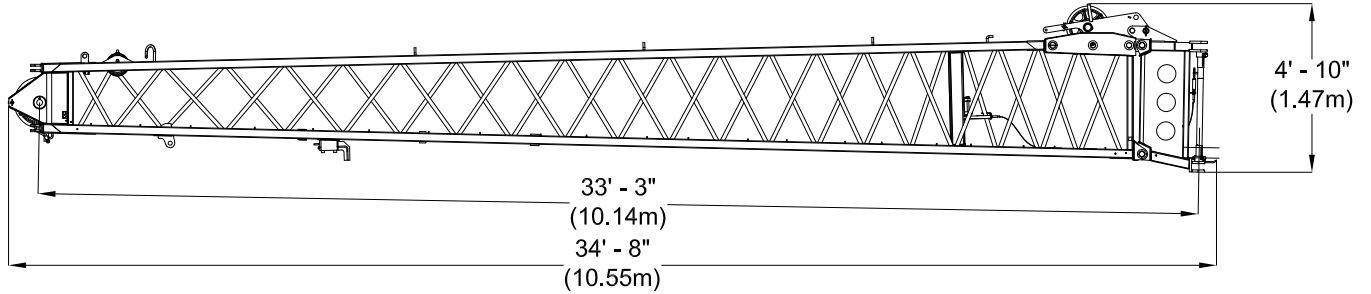

33' 3" EXTENSION (10.1m)
WEIGHT: 2030 lb (919 kg)

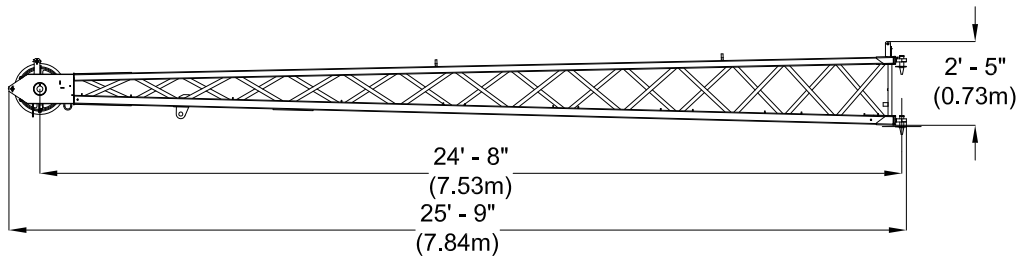

24' 8" JIB POINT (7.5m)
WEIGHT: 750 lb (339 kg)

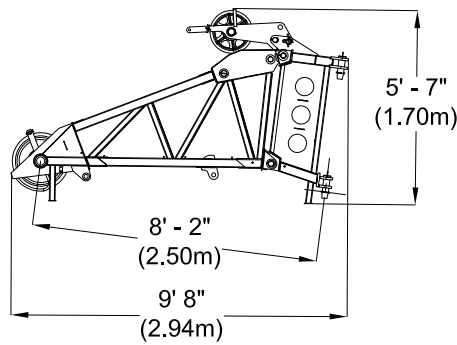

8' 2" HEAVY LIFT JIB (2.5m)
WEIGHT: 972 lb (441 kg)

TRANSPORT DIMENSIONS

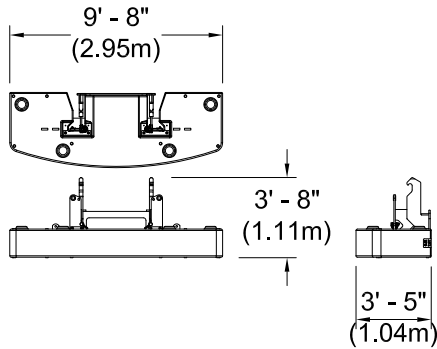

CONFIGURATION "A"
WEIGHT: 15,000 lb (6804 kg)

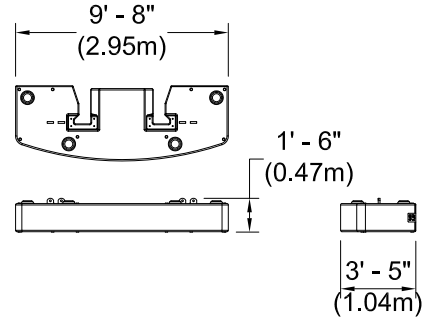

CWT "B" SECTION
WEIGHT: 15,000 lb (6804 kg)

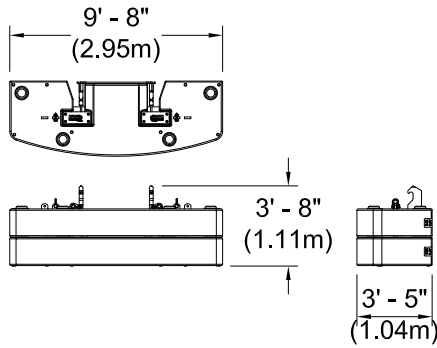

CONFIGURATION "B"
WEIGHT: 30,000 lb (13607 kg)

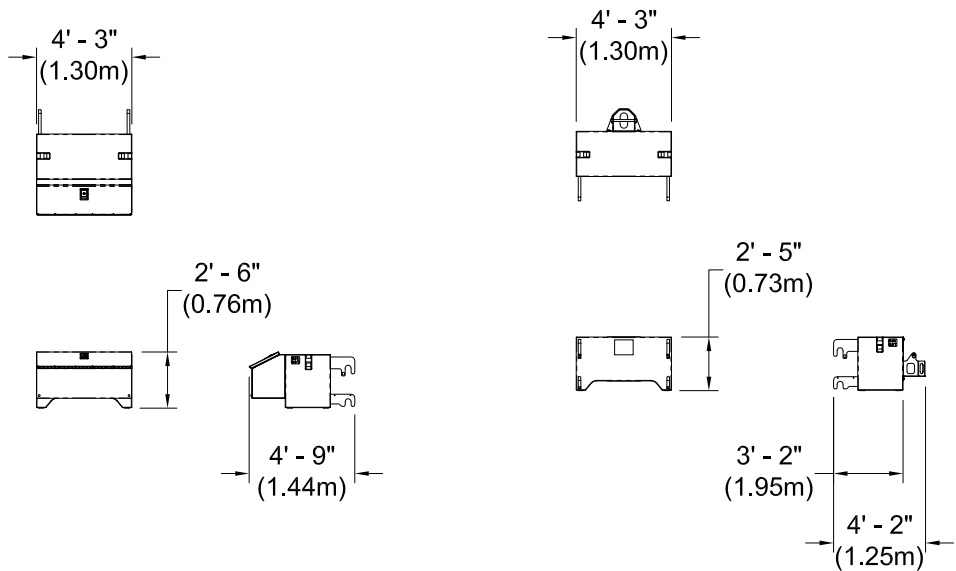

REAR CARBODY CWT
WEIGHT: 6,613 lb (3000 kg)

FRONT CARBODY CWT
WEIGHT: 6,613 lb (3000 kg)

WORKING RANGE DIAGRAM

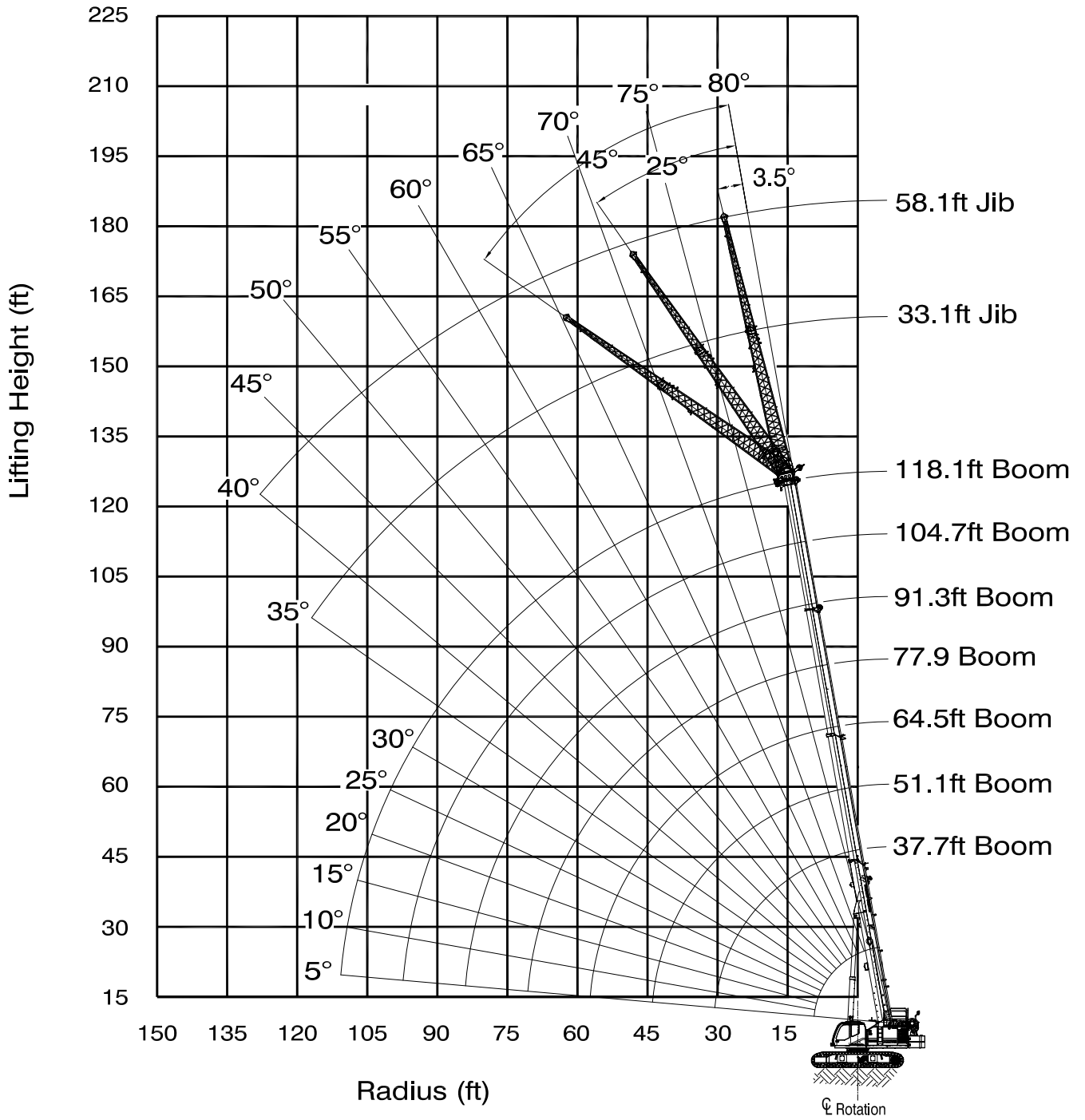

WORKING RANGE DIAGRAM - HEAVY LIFT JIB

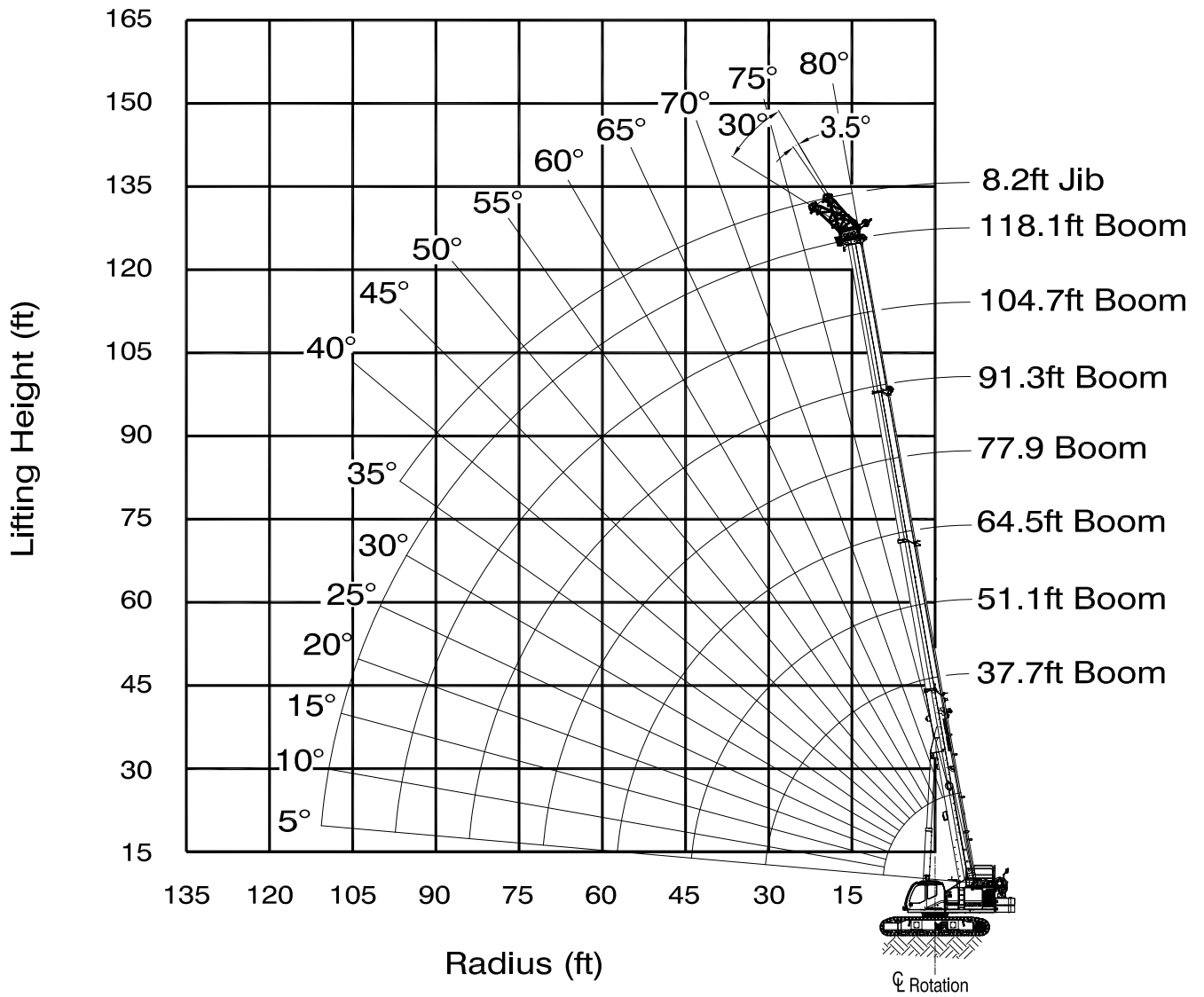

LOAD CHARTS

LOADS IN lb x 1000

MAIN BOOM with TRACKS FULLY EXTENDED - 360° UP to 1.5° SLOPE								
30,000 lb MAIN COUNTERWEIGHT AND 13,200 lb CARBODY COUNTERWEIGHT								
RADIUS (ft)	MAIN BOOM LENGTH (ft)						RADIUS (ft)	
	37.7	51.1	64.5	77.9	91.3	104.7		118.1
10	132.3	115.5	78.8	38.6				10
12	121.6	115.5	77.6	38.6				12
15	96.7	95.8	76.1	37.1	36.4			15
20	69.7	66.4	63.6	37.1	36.2	34.5	29.8	20
25	49.9	47.5	45.6	37.1	36.1	34.2	29.4	25
30	38.6	37.3	36.1	35.5	35.5	33.7	26.2	30
35		31.1	31.1	29.6	28.5	28.5	23.5	35
40		25.8	25.9	25.9	23.6	23.7	21.3	40
45			22.0	22.0	19.8	20.0	19.4	45
50			19.0	19.0	16.9	17.1	17.4	50
55			16.6	16.6	14.5	15.2	15.1	55
60				14.6	12.6	13.9	13.2	60
65				13.1	11.5	12.3	11.6	65
70				11.8	10.7	10.9	10.3	70
75					10.0	9.8	9.1	75
80					9.3	8.8	8.1	80
85						7.9	7.2	85
90						7.1	6.5	90
95						6.5	5.8	95
100							5.2	100
105							4.7	105
110							4.2	110
PARTS OF LINE	10	8	8	4	4	4	2	PARTS OF LINE

Load chart data is for reference, load charts supplied in the crane cab shall be used for lift planning.

LOAD CHARTS

LOADS IN lb x 1000

MAIN BOOM with TRACKS FULLY EXTENDED - 360° UP to 4° SLOPE 30,000 lb MAIN COUNTERWEIGHT AND 13,200 lb CARBODY COUNTERWEIGHT								
RADIUS (ft)	MAIN BOOM LENGTH (ft)						RADIUS (ft)	
	37.7	51.1	64.5	77.9	91.3	104.7		118.1
10	130.2	96.0	77.0	38.6				10
12	119.0	96.0	77.0	38.6				12
15	90.3	80.5	72.8	37.1	36.4			15
20	60.7	54.9	50.5	37.1	36.2	31.4	25.3	20
25	45.3	41.0	37.9	37.1	36.1	31.4	25.3	25
30	36.3	34.5	33.4	30.6	29.0	28.2	23.3	30
35		27.6	27.6	26.8	23.9	23.4	21.2	35
40		22.5	23.3	22.7	20.0	19.8	19.4	40
45			20.1	19.6	17.1	16.9	16.9	45
50			17.6	17.1	14.7	15.4	14.7	50
55			15.7	15.1	12.9	13.8	12.9	55
60				13.5	11.9	12.3	11.4	60
65				12.2	11.1	10.9	10.1	65
70				11.2	10.4	9.8	9.0	70
75					9.7	8.8	8.0	75
80					9.0	8.0	7.1	80
85						7.2	6.4	85
90						6.6	5.8	90
95						6.1	5.2	95
100							4.7	100
105							4.3	105
110							3.9	110
PARTS OF LINE	10	8	8	4	4	4	2	PARTS OF LINE

Load chart data is for reference, load charts supplied in the crane cab shall be used for lift planning.

LOAD CHARTS

LOADS IN lb x 1000

MAIN BOOM with TRACKS RETRACTED - OVER FRONT/REAR UP to 1.5° SLOPE								
30,000 lb MAIN COUNTERWEIGHT AND 13,200 lb CARBODY COUNTERWEIGHT								
RADIUS (ft)	MAIN BOOM LENGTH (ft)							RADIUS (ft)
	37.7	51.1	64.5	77.9	91.3	104.7	118.1	
10	132.3	115.5	78.8	38.6				10
12	121.6	115.5	77.6	38.6				12
15	96.7	95.8	76.1	37.1	36.4			15
20	70.9	70.0	67.4	37.1	36.2	34.5	29.8	20
25	55.2	54.3	53.7	37.1	36.1	34.2	29.4	25
30	44.7	43.8	42.8	37.1	36.1	33.7	26.2	30
35		37.3	36.1	34.5	32.9	29.9	23.5	35
40		31.2	31.1	28.3	28.5	26.7	21.3	40
45			26.4	24.7	24.0	24.0	19.4	45
50			22.8	22.7	20.5	20.7	17.9	50
55			20.0	19.9	17.7	17.9	16.5	55
60				17.6	15.5	15.7	15.3	60
65				15.7	13.6	13.8	14.2	65
70				14.2	12.0	12.3	12.6	70
75					10.7	11.3	11.3	75
80					9.6	10.6	10.1	80
85						9.8	9.1	85
90						8.9	8.2	90
95						8.1	7.4	95
100							6.7	100
105							6.1	105
110							5.6	110
PARTS OF LINE	10	8	8	4	4	4	2	PARTS OF LINE

Load chart data is for reference, load charts supplied in the crane cab shall be used for lift planning.

LOAD CHARTS

LOADS IN lb x 1000

MAIN BOOM with TRACKS FULLY RETRACTED - OVER SIDE								
UP to 1.5° SLOPE								
30,000 lb MAIN COUNTERWEIGHT AND 13,200 lb CARBODY COUNTERWEIGHT								
RADIUS (ft)	MAIN BOOM LENGTH (ft)							RADIUS (ft)
	37.7	51.1	64.5	77.9	91.3	104.7	118.1	
10	*	*	*	*				10
12	*	*	*	*				12
15	*	*	*	*	*			15
20	42.0	*	*	*	*	*	*	20
25	30.9	31.5	28.0	*	*	*	*	25
30	24.1	24.6	24.7	24.7	22.4	23.6	22.3	30
35		19.8	20.0	20.1	20.2	19.2	18.4	35
40		16.4	16.6	16.7	16.9	16.0	15.2	40
45			14.0	14.1	14.3	13.5	12.7	45
50			12.0	12.1	12.3	11.5	10.8	50
55			10.4	10.5	10.7	9.9	9.2	55
60				9.1	9.3	8.6	7.9	60
65				8.0	8.2	7.4	6.8	65
70				7.2	7.2	6.5	5.8	70
75					6.4	5.6	5.0	75
80					5.7	4.9	4.3	80
85						4.3	3.7	85
90						3.8	3.1	90
95						3.3	2.5	95
100							2.0	100
105							1.5	105
110							1.1	110
PARTS OF LINE	10	8	8	4	4	4	2	PARTS OF LINE

Load chart data is for reference, load charts supplied in the crane cab shall be used for lift planning.

LOAD CHARTS

LOADS IN lb x 1000

MAIN BOOM with TRACKS FULLY EXTENDED - 360° UP to 1.5° SLOPE								
0 lb MAIN COUNTERWEIGHT AND 13,200 lb CARBODY COUNTERWEIGHT								
RADIUS (ft)	MAIN BOOM LENGTH (ft)							RADIUS (ft)
	37.7	51.1	64.5	77.9	91.3	104.7	118.1	
10	113.0	112.2	78.8	38.6				10
12	93.7	89.4	77.6	38.6				12
15	63.2	59.1	55.6	37.1	36.4			15
20	38.3	37.3	36.1	34.6	33.4	31.6	29.8	20
25	26.6	27.3	27.4	27.2	24.5	25.0	22.6	25
30	19.8	20.5	20.7	20.7	20.8	19.6	17.7	30
35		16.0	16.3	16.4	16.5	15.5	14.1	35
40		12.8	13.1	13.3	13.5	12.5	11.4	40
45			10.8	10.9	11.2	10.3	9.3	45
50			9.0	9.1	9.4	8.5	7.7	50
55			7.6	7.7	7.9	7.1	6.3	55
60				6.5	6.7	6.0	5.2	60
65				5.6	5.8	5.0	4.3	65
70				4.9	5.0	4.2	3.5	70
75					4.3	3.5	2.7	75
80					3.7	2.8	2.0	80
85						2.2	*	85
90						1.6	*	90
95						1.2	*	95
100							*	100
105							*	105
110							*	110
PARTS OF LINE	10	8	8	4	4	4	2	PARTS OF LINE

Load chart data is for reference, load charts supplied in the crane cab shall be used for lift planning.

LOAD CHARTS

LOADS IN lb x 1000

AUX NOSE SHEAVE with TRACKS FULLY EXTENDED - 360° UP to 1.5° SLOPE								
30,000 lb MAIN COUNTERWEIGHT AND 13,200 lb CARBODY COUNTERWEIGHT								
RADIUS (ft)	MAIN BOOM LENGTH (ft)							RADIUS (ft)
	37.7	51.1	64.5	77.9	91.3	104.7	118.1	
10	14.6	14.6	14.6					10
12	14.6	14.6	14.6	14.6				12
15	14.6	14.6	14.6	14.6	14.6			15
20	14.6	14.6	14.6	14.6	14.6	14.6		20
25	14.6	14.6	14.6	14.6	14.6	14.6	14.6	25
30	14.6	14.6	14.6	14.6	14.6	14.6	14.6	30
35		14.6	14.6	14.6	14.6	14.6	14.6	35
40		14.6	14.6	14.6	14.6	14.6	14.6	40
45		14.6	14.6	14.6	14.6	14.6	14.6	45
50			14.6	14.6	14.6	14.6	14.6	50
55			14.6	14.6	14.6	14.6	14.6	55
60			14.6	14.6	13.0	13.3	13.5	60
65				13.3	11.4	11.9	11.9	65
70				11.9	10.0	11.1	10.5	70
75					9.1	10.0	9.3	75
80					8.5	9.0	8.4	80
85					8.0	8.1	7.5	85
90						7.3	6.7	90
95						6.6	6.0	95
100						6.1	5.4	100
105							4.8	105
110							4.3	110
PARTS OF LINE	1	1	1	1	1	1	1	PARTS OF LINE

Load chart data is for reference, load charts supplied in the crane cab shall be used for lift planning.

LOAD CHARTS

LOADS IN lb x 1000

8.2FT JIB with TRACKS FULLY EXTENDED - 360°											
UP to 1.5° SLOPE											
30,000 lb MAIN COUNTERWEIGHT AND 13,200 lb CARBODY COUNTERWEIGHT											
RADIUS (ft)	MAIN BOOM LENGTH (ft)										RADIUS (ft)
	37.7		77.9		91.3		104.7		118.1		
	3.5°	30°	3.5°	30°	3.5°	30°	3.5°	30°	3.5°	30°	
10	44.8	35.1									10
12	43.1	34.2									12
15	40.9	33.2	33.3	32.6							15
20	37.9	31.9	27.3	26.9	24.2	26.2	28.2				20
25	35.7	31.2	27.0	26.6	23.1	22.5	24.5	23.6	25.3	24.2	25
30	34.3	31.2	26.7	26.3	20.1	19.7	21.5	20.9	22.5	21.6	30
35	31.2	31.2	26.3	25.6	17.7	17.4	19.1	18.6	20.2	19.5	35
40			23.9	23.4	15.7	15.5	17.2	16.8	18.2	17.7	40
45			21.7	21.5	14.1	14.0	15.5	15.2	16.6	16.2	45
50			18.7	18.9	12.7	12.7	14.1	13.9	15.2	14.8	50
55			16.2	16.4	11.6	11.5	12.9	12.7	14.0	13.7	55
60			14.2	14.4	10.6	10.5	11.8	11.7	12.7	12.7	60
65			12.6	12.7	9.7	9.7	10.9	10.8	11.0	11.3	65
70			11.2	11.3	8.9	8.9	10.1	10.1	9.7	9.9	70
75			10.1		8.3	8.3	9.2	9.3	8.5	8.7	75
80					7.7	7.7	8.2	8.3	7.5	7.7	80
85					7.1		7.3	7.4	6.7	6.8	85
90					6.7		6.5	6.6	5.9	6.0	90
95							5.8		5.2	5.2	95
100							5.2		4.6	4.6	100
105							4.7		4.0	4.1	105
110									3.4		110
115									2.9		115
PARTS OF LINE	4	4	2	2	2	2	2	2	2	2	PARTS OF LINE

Load chart data is for reference, load charts supplied in the crane cab shall be used for lift planning.

LOAD CHARTS

LOADS IN lb x 1000

33.1FT JIB with TRACKS FULLY EXTENDED - 360°																
UP to 1.5° SLOPE																
30,000 lb MAIN COUNTERWEIGHT AND 13,200 lb CARBODY COUNTERWEIGHT																
RADIUS (ft)	MAIN BOOM LENGTH (ft)															RADIUS (ft)
	37.7			77.9			91.3			104.7			118.1			
	3.5°	25°	45°	3.5°	25°	45°	3.5°	25°	45°	3.5°	25°	45°	3.5°	25°	45°	
10	14.6															10
12	14.6															12
15	14.6															15
20	14.6			14.6			*									20
25	14.6	14.6		14.6			14.6			14.6						25
30	14.6	14.0	11.8	14.6	14.6		14.6			14.6			13.3			30
35	14.6	13.0	11.1	14.6	14.5		14.6	14.0		14.6			13.3			35
40	14.6	12.1	10.6	14.6	13.8	11.2	14.1	13.4		14.6	13.9		13.3	14.0		40
45	13.5	11.3	10.2	14.6	13.1	10.8	13.5	12.8	10.9	14.0	13.1	11.0	13.3	13.1		45
50	12.4	10.7	9.9	14.6	12.5	10.5	12.3	11.9	10.6	12.9	12.1	10.7	13.1	12.1	10.7	50
55	11.5	10.3	9.8	14.6	11.9	10.2	11.3	10.9	10.3	11.8	11.2	10.4	12.1	11.3	10.5	55
60	10.8	10.0		13.7	11.4	10.0	10.4	10.1	10.0	11.0	10.4	10.2	11.2	10.6	10.2	60
65				12.9	11.0	9.8	9.6	9.4	9.3	10.2	9.7	9.5	10.5	9.9	9.6	65
70				12.2	10.7	9.6	8.9	8.7	8.6	9.5	9.1	9.0	9.8	9.3	9.1	70
75				11.0	10.3	9.5	8.3	8.1	8.1	8.9	8.6	8.4	9.2	8.8	8.6	75
80				10.0	10.1	9.4	7.7	7.6	7.6	8.3	8.0	7.9	8.4	8.3	8.1	80
85				9.1	9.4	9.4	7.2	7.1	7.1	7.8	7.6	7.5	7.5	7.8	7.7	85
90				8.3	8.6		6.8	6.7	6.7	7.3	7.2	7.1	6.7	7.3	7.3	90
95				7.6	7.8		6.3	6.3	6.3	6.7	6.8	6.7	6.1	6.5	6.8	95
100				7.0	7.1		6.0	5.9		6.1	6.4	6.4	5.4	5.9	6.1	100
105				6.5			5.6	5.6		5.5	5.8	6.0	4.9	5.3	5.5	105
110							5.4	5.3		5.0	5.2		4.4	4.7	4.9	110
115							5.1			4.5	4.7		3.9	4.2	4.3	115
120										4.1	4.3		3.5	3.7		120
125										3.7	3.9		3.0	3.3		125
130										3.4			2.6	2.8		130
135													2.2	2.4		135
140													1.9			140
145													1.6			145
PARTS OF LINE	1	1	1	1	1	1	1	1	1	1	1	1	1	1	1	PARTS OF LINE

Load chart data is for reference, load charts supplied in the crane cab shall be used for lift planning.

LOAD CHARTS

LOADS IN lb x 1000

58.1FT JIB with TRACKS FULLY EXTENDED - 360°																
UP to 1.5° SLOPE																
30,000 lb MAIN COUNTERWEIGHT AND 13,200 lb CARBODY COUNTERWEIGHT																
RADIUS (ft)	MAIN BOOM LENGTH (ft)															RADIUS (ft)
	37.7			77.9			91.3			104.7			118.1			
	3.5°	25°	45°	3.5°	25°	45°	3.5°	25°	45°	3.5°	25°	45°	3.5°	25°	45°	
10																10
12																12
15																15
20	9.8															20
25	9.8			*												25
30	9.8			8.1			7.6			*						30
35	9.6			8.1			7.6			7.3			*			35
40	8.8	7.9		8.1			7.6			7.3			7.0			40
45	8.0	7.5		8.1	7.9		7.6			7.3			7.0			45
50	7.4	7.0	6.0	8.1	7.5		7.6	7.6		7.3			7.0			50
55	6.9	6.6	5.6	8.1	7.2		7.6	7.3		7.3	7.3		7.0	*		55
60	6.4	6.1	5.4	7.8	6.9	5.6	7.6	7.0		7.3	7.1		7.0	7.0		60
65	6.0	5.7	5.1	7.4	6.6	5.4	7.6	6.8	5.5	7.3	6.9		7.0	6.9		65
70	5.7	5.4	4.9	7.0	6.3	5.2	7.3	6.5	5.3	7.3	6.6	5.3	7.0	6.7	*	70
75	5.4	5.1	4.7	6.7	6.0	5.1	6.9	6.2	5.1	7.1	6.4	5.2	7.0	6.5	5.2	75
80	5.1	4.8	4.6	6.4	5.8	4.9	6.6	5.9	5.0	6.9	6.1	5.0	7.0	6.2	5.1	80
85	4.9	4.6		6.1	5.5	4.8	6.3	5.7	4.9	6.6	5.9	4.9	6.7	6.0	5.0	85
90				5.9	5.3	4.7	5.9	5.5	4.7	6.3	5.6	4.8	6.5	5.8	4.8	90
95				5.6	5.1	4.6	5.5	5.3	4.6	5.9	5.4	4.7	6.2	5.6	4.7	95
100				5.4	4.9	4.5	5.2	5.1	4.5	5.6	5.3	4.6	5.8	5.4	4.6	100
105				5.2	4.8	4.4	4.9	4.9	4.5	5.2	5.1	4.5	5.3	5.2	4.5	105
110				5.1	4.6	4.4	4.6	4.6	4.4	5.0	4.9	4.4	4.8	5.0	4.5	110
115				4.9	4.5		4.3	4.3	4.3	4.7	4.6	4.4	4.3	4.8	4.4	115
120				4.8	4.4		4.1	4.1	4.1	4.5	4.4	4.3	3.9	4.5	4.3	120
125				4.7	4.4		3.9	3.9		4.1	4.2	4.2	3.5	4.0	4.3	125
130							3.7	3.7		3.7	4.0	4.0	3.1	3.6	3.9	130
135							3.5	3.5		3.4	3.7		2.7	3.2	3.4	135
140							3.3			3.1	3.4		2.3	2.8		140
145										2.8	3.0		2.0	2.4		145
150										2.5	2.6		1.7	2.0		150
155										2.2			1.4	1.7		155
PARTS OF LINE	1	1	1	1	1	1	1	1	1	1	1	1	1	1	1	PARTS OF LINE

Load chart data is for reference, load charts supplied in the crane cab shall be used for lift planning.

WP750 WORK PLATFORM ON MAIN BOOM RANGE CHART FOR MANTIS MODEL GTC-600

as originally manufactured and equipped by Tadano Mantis Corporation

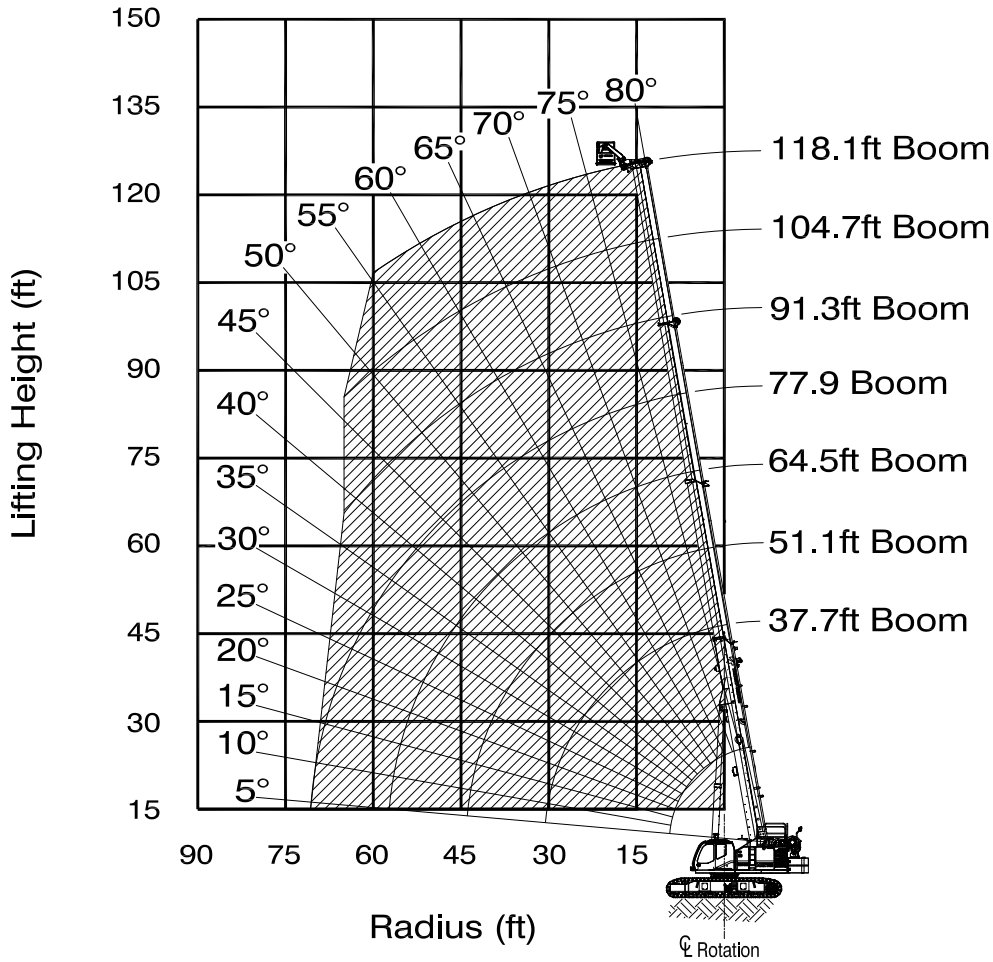

Shaded Area is Allowable Operating Range

Limits of operation:

Maximum load capacity = 750 lb

Maximum radius when mounted on main boom = 95 ft

Maximum occupancy = 2 persons

Notes:

1. It is permissible to leave the jibs stowed on the boom while operating with Work Platform mounted to the main boom.
2. The hook block(s) must be removed when using the Work Platform

WARNING: Lifting a load during Work Platform operation is not allowed.

WARNING: Travelling the crane with person(s) in the Work Platform is not allowed.

WP750 WORK PLATFORM ON 33.5 FT (10.2 M) EXTENSION RANGE CHART FOR MANTIS MODEL GTC-600

as originally manufactured and equipped by Tadano Mantis Corporation

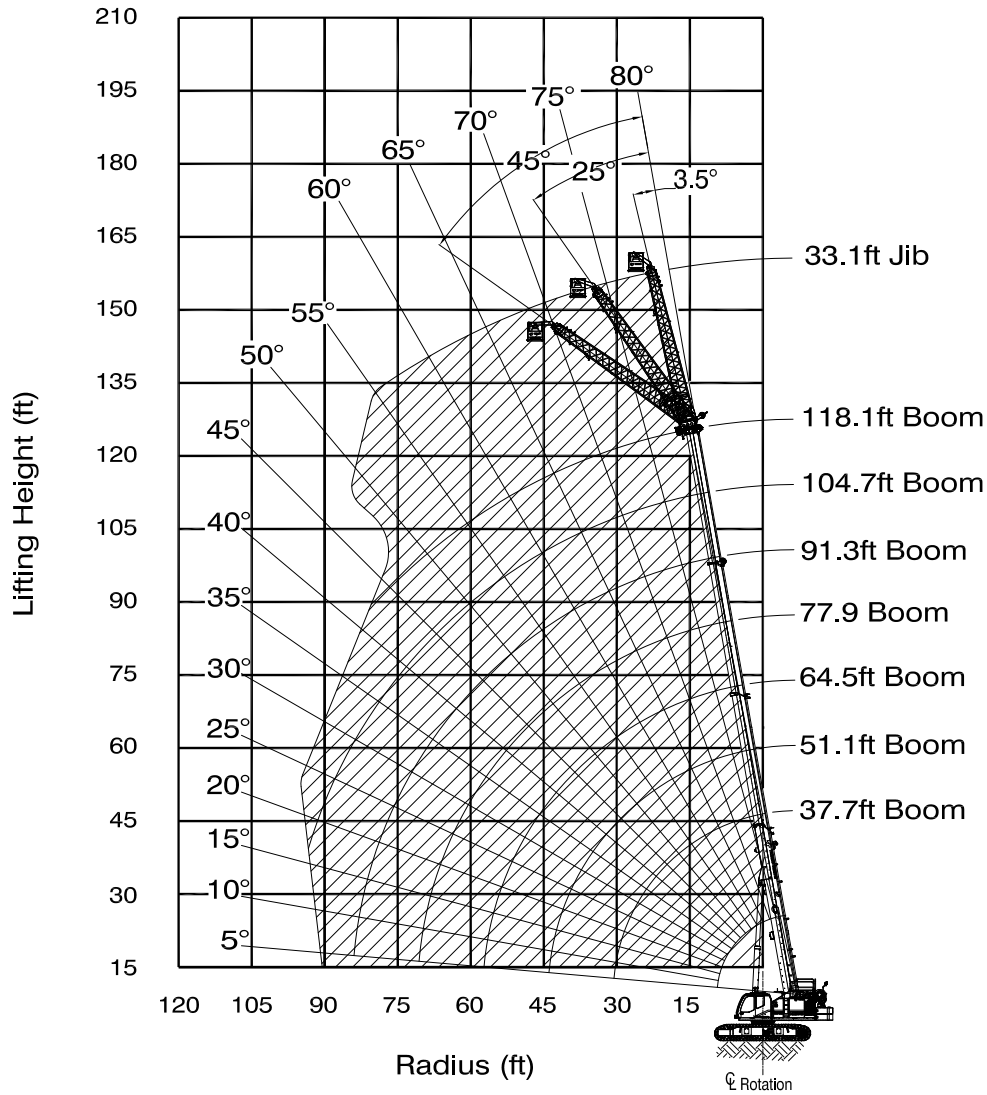

Shaded Area is Allowable Operating Range

Limits of operation:

Minimum boom angle when mounted on 33.5ft (10.2m) extension at 0° offset = 0°

Minimum boom angle when mounted on 33.5ft (10.2m) extension at 20° offset = 20°

Minimum boom angle when mounted on 33.5ft (10.2m) extension at 40° offset = 40°

Maximum occupancy = 2 persons

Notes:

1. It is permissible to leave the jib section stowed on the boom while operating with Work Platform mounted to the 33.5 ft (10.2m) jib.
2. The hook block(s) must be removed when using the Work Platform

WARNING: Lifting a load during Work Platform operation is ***not*** allowed.

WARNING: Travelling the crane with person(s) in the Work Platform is ***not*** allowed.

PLEASE READ, UNDERSTAND, AND FOLLOW THE MANUALS FURNISHED WITH THE CRANE AS WELL AS THE CAPACITY LIMITATIONS AND GENERAL CONDITIONS LISTED BELOW PRIOR TO OPERATION OF THE CRANE. FAILURE TO DO SO MAY RESULT IN AN ACCIDENT.

Performance of this TADANO MANTIS crane as manufactured by Tadano Mantis Corporation applies only to machines as originally equipped by the manufacturer and in a properly maintained condition. Capacities given are maximum covered by the manufacturer's warranty and are based on a freely suspended load with NO allowance for factors as out-of-level operation (beyond the limits specified on the charts), supporting surface conditions, hazardous surroundings, experience of personnel, etc. The operator shall establish practical working loads based on prevailing operating conditions, such as, but not limited to the above.

The crane meets the requirements of ASME B30.5. Structure and Stability have been tested in accordance with SAE J1063 and SAE J765, respectively.

Maximum admissible wind velocity for working with telescopic boom and jibs is 20 mph. Consult TADANO MANTIS for ratings at higher wind speeds.

Side pull on boom is extremely dangerous and must be avoided.

DO NOT exceed manufacturers maximum specified reeving.

Boom angle/boom length relationships given are an approximation of the resulted load radius, which should be an accurate measurement. Boom height dimensions are measured from ground to center of lower boom head sheave.

It is permissible to attempt to telescope boom with a load within the limits of rated capacities. However, boom angle system hydraulic pressure, and/or boom lubrication may affect operation.

It is permissible to travel with loads within the rated capacity of the crane. Travel speeds should be greatly reduced to reflect terrain limitations and minimize dynamic loads applied to the crane structure.

Lifting capacities are shown in lbs x 1000.

The weight of load handling devices such as hook blocks, slings, etc., must be considered as part of the load and must be deducted from the lifting capacities.

The lifting capacities for the telescopic boom apply to a crane with no jibs or other optional equipment stowed or mounted on the crane.

The working radius is the horizontal distance from the center of rotation to the center of the freely suspended, non-oscillating load.

The lifting capacities are subject to change without prior notice.

The above remarks are for basic information only and the operator's manual must be consulted before operating this crane. All data and performances refer to the standard crane. The addition of optional and other non-standard equipment may affect the performance of the crane.

Load moment indicating and anti-two block systems are operator aids and must never be used in lieu of job site lift planning calculations by the operator which must take into account ground conditions, weather and all other environmental factors prevailing at the time of the lift. Specifications are subject to change at any time without prior notice. Illustrations and photographs may show optional equipment. Supersedes all previous issues.

TADANO MANTIS CORPORATION

1705 Columbia Avenue • Franklin, TN 37064 USA • Toll-Free: 1-800-272-3325 • Fax: 615-790-6803 • mantiscranes.com

TADANO Ltd., International Division

4-12, Kamezawa 2-chome,
Sumida-Ku, Tokyo 130-0014, Japan

Tel: +81 3 3621 7750

Fax: +81 3 3621 7785

E-mail: info@tadano.com

www.tadano.com

SPECIFICATION SHEET NO. TMC-DI-734-14 02/17