

Technical data
Hydraulic crawler crane

HS 825 HD
Litronic®

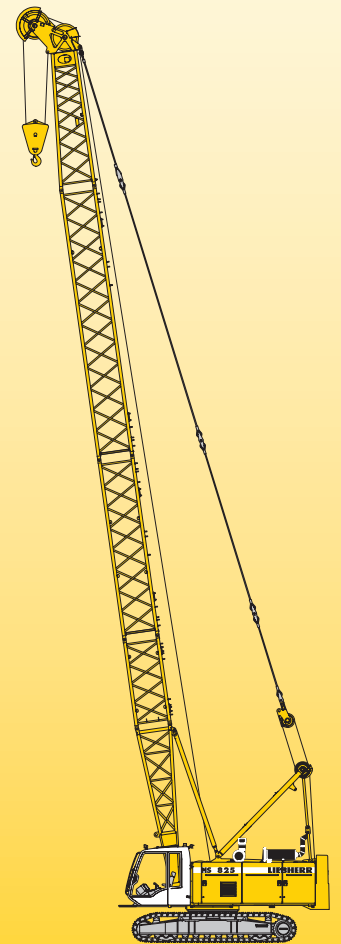

LIEBHERR

Dimensions

Basic machine with undercarriage

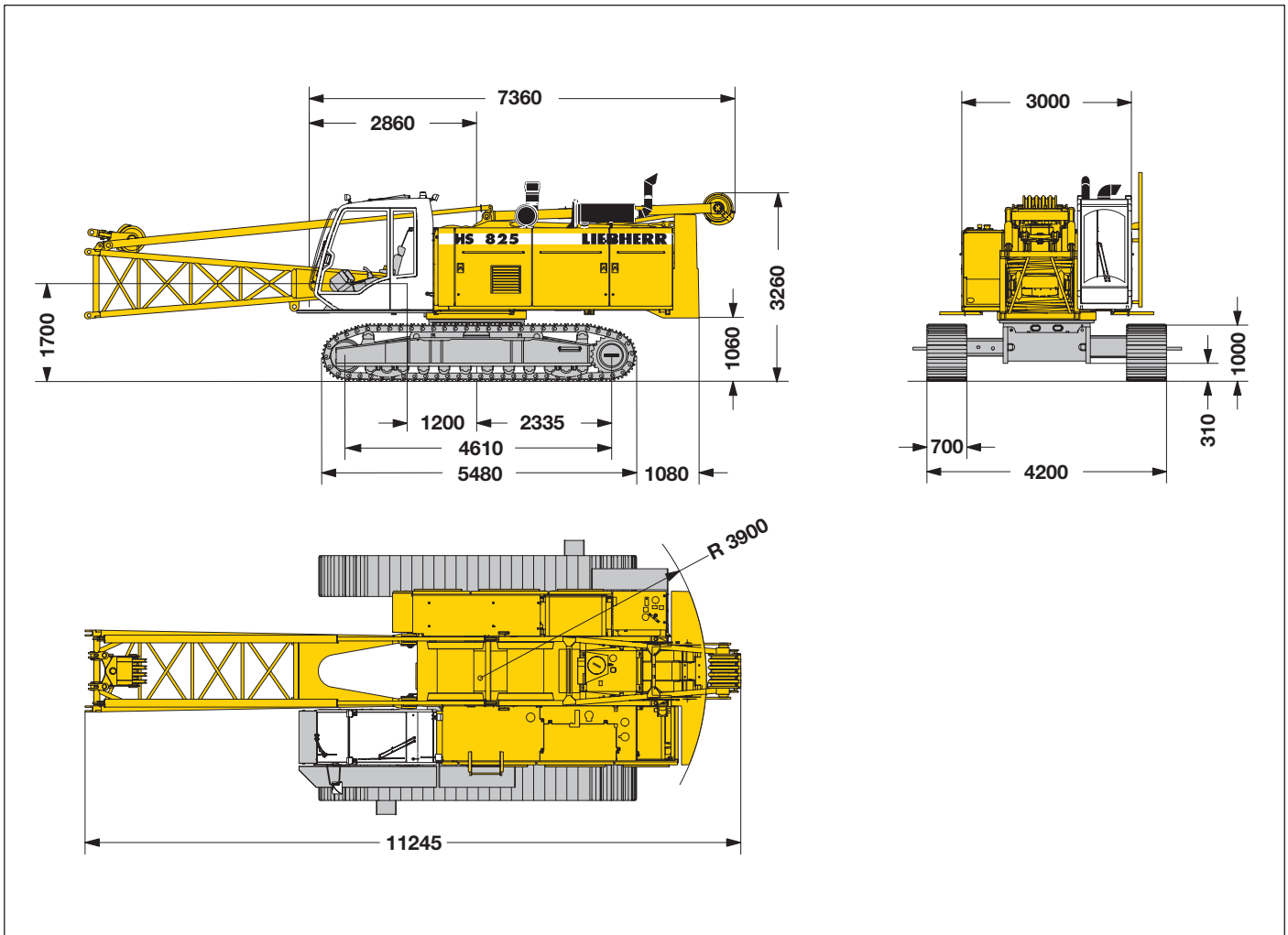

Operating weight

The operating weight includes the basic machine with HD undercarriage, 2 main winches 160 kN including wire ropes (60 m) and 11 m main boom, consisting of A-frame, pulley block, boom foot (5.5 m) and boom head (5.5 m), 12.8 t basic counterweight, 700 mm triple grouser track shoes and 50 t hook block.

Total weight approx. _____ 53 t

Ground pressure

Ground bearing pressure _____ 1.0 kg/cm²

Equipment

Standard main boom (No. 1310.17) max. length _____ 47 m
 Fixed jib _____ upon request
 Modular designed equipment for operation as crane, with dragline or clamshell.
 For dragline operation, a rotating fairlead is fitted into the boom foot. This minimizes the rope angle to drum, which results in lower rope wear.

Remarks

1. The lifting capacities stated are valid for lifting operation only (corresponding with crane classification according to F.E.M. 1.001, crane group A1).
2. Crane standing on firm, horizontal ground.
3. The weight of the lifting device (hoisting ropes, hook block, shackle etc.) must be deducted from the gross lifting capacity to obtain a net lifting value.
4. Additional equipment on boom (e.g. boom walkways, auxiliary jib) must be deducted to get the net lifting capacity.
5. For max. wind speed please refer to lift chart in operator's cab or manual.
6. Working radii are measured from center of swing and under load.
7. The lifting capacities are valid for 360 degrees of swing.
8. Calculation of stability under load is based on ISO 4305 Table 1 + 2, tipping angle 4°.
9. The structures are calculated according to F.E.M. 1.001 - 1998 (EN 13001-2 / 2004).

Transport dimensions and weights

Basic machine and boom (No. 1310.17)

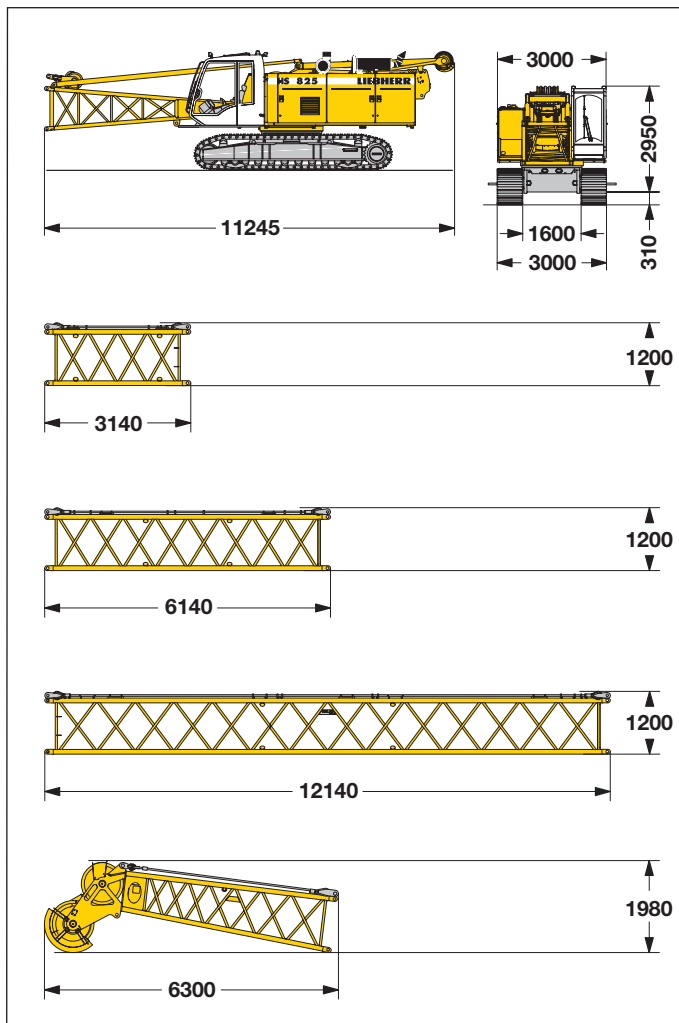

Basic machine

with HD undercarriage, boom foot, pulley block, A-frame, 2x 160 kN winches including wire ropes (60 m), without basic counterweight

Width	3000 mm
Weight	37000 kg

Boom section (No. 1310.17)

3 m

Width	1400 mm
Weight*	300 kg

Boom section (No. 1310.17)

6 m

Width	1400 mm
Weight*	480 kg

Boom section (No. 1310.17)

12 m

Width	1400 mm
Weight*	880 kg

Boom head (No. 1310.17)

Width	1400 mm
Weight*	1140 kg

Counterweight

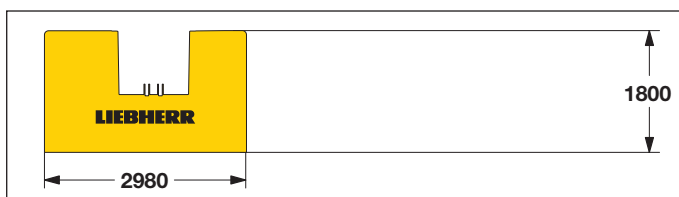

*) Including pendants

Counterweight

Width	930 mm
Weight*	12800 kg

Hooks

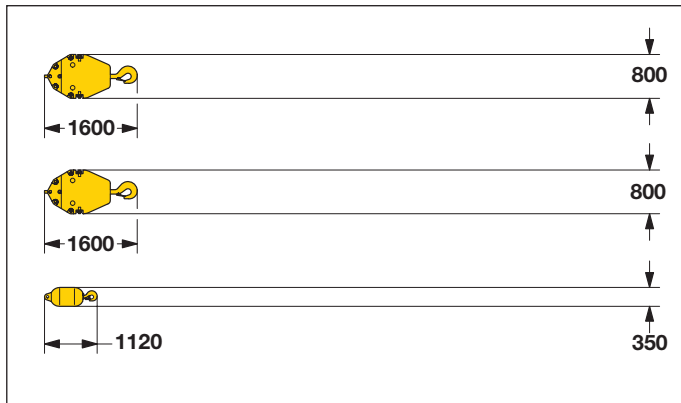

50 t hook block - 2 sheaves

Width	500 mm
Weight	1600 kg

32 t hook block - 1 sheave

Width	500 mm
Weight	1500 kg

12 t single hook

Width	400 mm
Weight	600 kg

Technical description



Engine

Power rating according to ISO 9249, 180 kW (241 hp) at 2000 rpm

Engine type _____ Liebherr D 934 L A6

Fuel tank _____ 790 l capacity with continuous level
_____ indicator and reserve warning

Engine complies with NRMM exhaust certification EPA/CARB Tier 3 and 97/68 EC Stage III

Option:

Power rating according to ISO 9249, 270 kW (362 hp) at 2000 rpm

Engine type _____ Liebherr D 936 L A6

Fuel tank _____ 790 l capacity with continuous level
_____ indicator and reserve warning

Engine complies with NRMM exhaust certification EPA/CARB Tier 3 and 97/68 EC Stage III



Hydraulic system

A double axial displacement pump with integrated gearbox supplies the open loop hydraulic system, allowing all functions to be operated simultaneously. To minimize peak pressure an automatic working pressure cut-off is integrated in the pump. All filters are electronically monitored.

The use of synthetic environmentally friendly (biodegradable) oils is possible. Ready made hydraulic retrofit kits are available to customize requirements e. g. powering casing oscillators, VM vibrators, hydraulic grabs, hanging leads etc.

Working pressure _____ max. 350 bar

Oil tank capacity _____ 650 l



Boom winch

Line pull _____ max. 2x 50 kN

Rope diameter _____ 18 mm

Boom up _____ 55 sec. from 15° to 82°



Swing

Consists of rollerbearing with external teeth for lower tooth flank pressure, fixed axial piston hydraulic motor, spring loaded and hydraulically released multi-disc holding brake, planetary gearbox and pinion. Swing speed from 0 – 4.5 rpm continuously variable, selector for 3 speed ranges to increase swing precision.



Noise emission

Noise emissions correspond with 2000/14/EC directive on noise emission by equipment used outdoors.



Main winches

Winch options:

Line pull (nom. load) _____ 80 kN _____ 120 kN _____ 160 kN

Rope diameter _____ 20 mm _____ 24 mm _____ 26 mm

Drum diameter _____ 420 mm _____ 525 mm _____ 580 mm

Rope speed _____ 0–160 m/min - 0-130 m/min - 0-130 m/min

Rope capacity 1st layer _____ 40 m _____ 48.5 m _____ 51.9 m

The winches are outstanding in their compact design and easy assembly. Clutch and braking functions on the free fall system are provided by a compact designed, low wear and maintenance-free multi-disc brake.

The drag and hoist winches use pressure controlled, variable flow hydraulic motors.

This system features sensors that automatically adjust oil flow to provide max. winch speed depending on load.

Option:

Tagline winch _____ 20 kN with free fall



Crawlers

The track width of the undercarriage is changed hydraulically. Propulsion through axial piston motor, hydraulically released spring loaded multi-disc brake, maintenance-free crawler tracks, hydraulic chain tensioning device.

Flat or triple grouser track shoes _____ 700 mm

Drive speed _____ 0 – 1.85 km/h

Option:

- 2 speed hydraulic motor for higher travel speed



Control

The control system – developed and manufactured by Liebherr – is designed to withstand extreme temperature changes and the rough heavy duty tasks common in the construction industry. Complete machine operating data are shown on a high resolution display. The crane is equipped with proportional control for all movements, which can be carried out simultaneously.

Dragline operation: a special "Interlock" control system is an option available. It is designed for power lifting of the dragline bucket without using the drag winch brake.

On request, Liebherr also offers special custom designed control systems for free fall winches.

Operation: left joy stick for boom winch and swing, right two directional levers for winch I and II. Crawler control is actuated with the two central foot pedals. Additionally, hand levers can be attached to the pedals.

Options:

- Special demolition control system
- MDE: Machine data recording
- PDE: Process data recording
- GSM modem

Dragline equipment

12.7 t counterweight - standard main boom (No. 1310.17)

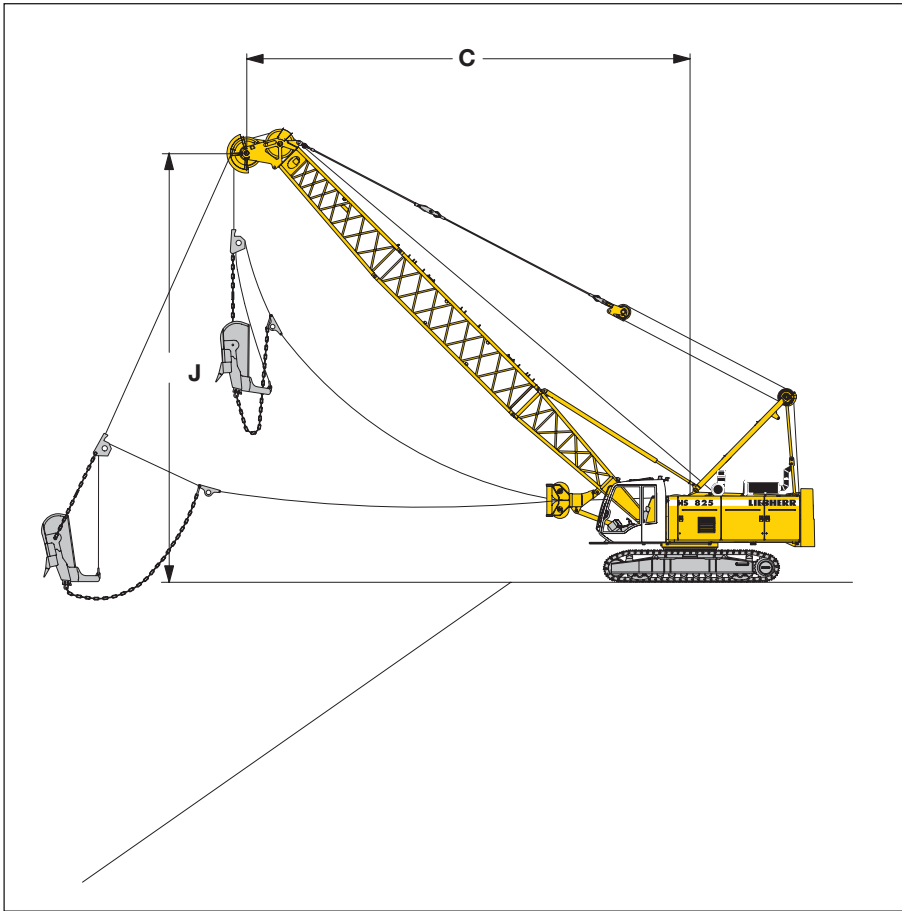

Working diagram

C = Radius / dumping radius
 J = Height of boom head sheave centre above ground level

Capacities in metric tons for boom lengths (11 m - 26 m)

counterweight 12.7 t

alpha	Boom length (m)																	
	11			14			17			20			23			26		
	C (m)	J (m)	t	C (m)	J (m)	t	C (m)	J (m)	t	C (m)	J (m)	t	C (m)	J (m)	t	C (m)	J (m)	t
45	9.8	9.0	12.1	11.9	11.1	9.3	14.0	13.3	7.4	16.1	15.4	6.0	18.3	17.5	5.1	20.4	19.6	4.2
40	10.4	8.3	11.1	12.7	10.2	8.5	15.0	12.1	6.7	17.3	14.1	5.5	19.6	16.0	4.6	21.9	17.9	3.7
35	10.9	7.5	10.4	13.4	9.2	7.9	15.8	10.9	6.2	18.3	12.6	5.0	20.7	14.4	4.2	23.2	16.1	3.4
30	11.4	6.6	9.8	14.0	8.1	7.4	16.6	9.6	5.8	19.2	11.1	4.7	21.8	12.6	3.9	24.4	14.1	3.1
25	11.8	5.8	9.4	14.5	7.0	7.0	17.2	8.3	5.5	19.9	9.6	4.4	22.7	10.8	3.6	25.4	12.1	2.9

Max. capacities in metric tons do not exceed 75% of tipping load.

Clamshell equipment

12.7 t counterweight - standard main boom (No. 1310.17)

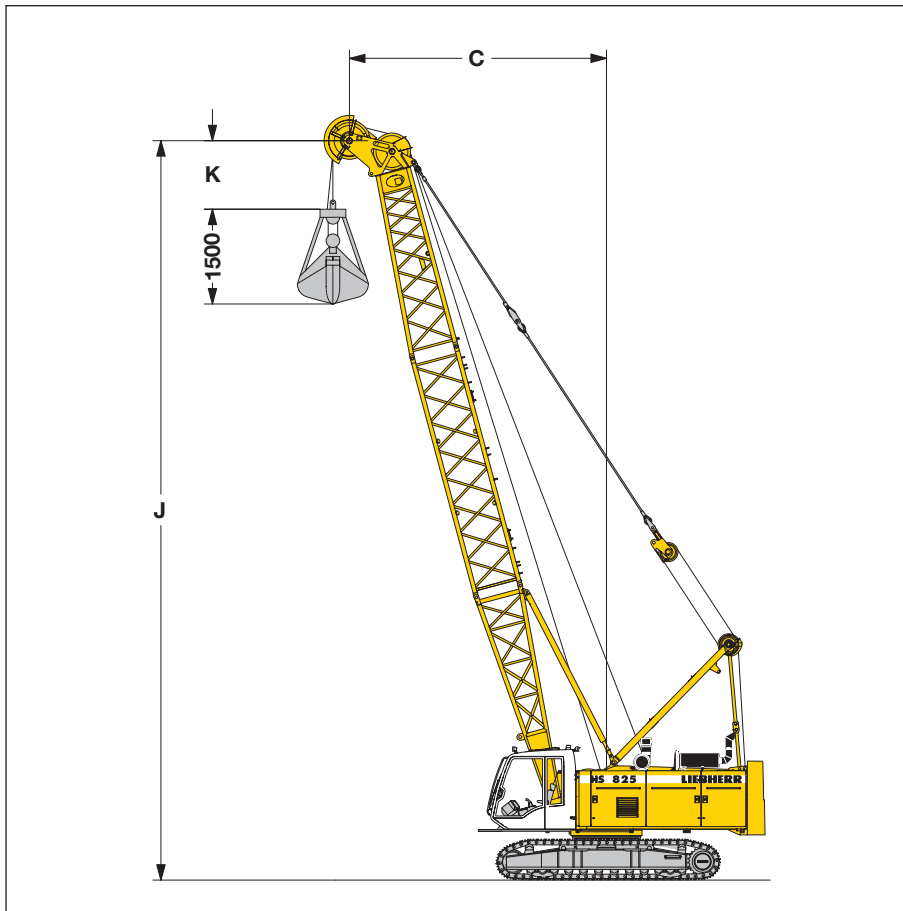

Working diagram

- C = Radius / dumping radius
- J = Height of boom head sheave centre above ground level
- K = Length of clamshell (depending on type and capacity of bucket)

Capacities in metric tons for boom lengths (11 m - 26 m)

counterweight 12.7 t

alpha	Boom length (m)																	
	11			14			17			20			23			26		
	C (m)	J (m)	t	C (m)	J (m)	t	C (m)	J (m)	t	C (m)	J (m)	t	C (m)	J (m)	t	C (m)	J (m)	t
65	6.8	11.4	16.6	8.0	14.1	14.0	9.3	16.8	11.4	10.6	19.6	9.6	11.8	22.3	8.2	13.1	25.0	7.1
60	7.6	10.9	15.1	9.1	13.5	11.8	10.6	16.1	9.6	12.1	18.7	7.9	13.6	21.3	6.8	15.1	23.9	5.8
55	8.4	10.3	13.2	10.1	12.8	10.2	11.8	15.3	8.2	13.5	17.7	6.8	15.3	20.2	5.8	17.0	22.6	4.9
50	9.1	9.7	11.7	11.0	12.0	9.0	13.0	14.3	7.3	14.9	16.6	6.0	16.8	18.9	5.0	18.7	21.2	4.2
45	9.8	9.0	10.7	11.9	11.1	8.1	14.0	13.3	6.5	16.1	15.4	5.3	18.3	17.5	4.4	20.4	19.6	3.7
40	10.4	8.3	9.8	12.7	10.2	7.5	15.0	12.1	5.9	17.3	14.1	4.8	19.6	16.0	4.0	21.9	17.9	3.3
35	10.9	7.5	9.1	13.4	9.2	6.9	15.8	10.9	5.5	18.3	12.6	4.4	20.7	14.4	3.7	23.2	16.1	3.0
30	11.4	6.6	8.6	14.0	8.1	6.5	16.6	9.6	5.1	19.2	11.1	4.1	21.8	12.6	3.4	24.4	14.1	2.8
25	11.8	5.8	8.2	14.5	7.0	6.2	17.2	8.3	4.9	19.9	9.6	3.9	22.7	10.8	3.2	25.4	12.1	2.6

Max. capacities in metric tons do not exceed 66.7% of tipping load.

Load diagram restricted by safety factors of standard ropes:

Winches ————— 120 kN — 160 kN

Rope diameter ——— 24 mm — 26 mm

Min. breaking load — 512 kN — 604 kN

1-rope clamshell ——— 10 t ——— 12 t

2-rope clamshell ——— 13.3 t ——— 16 t

Equipment (with standard main boom No. 1310.17)

Casing oscillator with corresponding undercarriage and slurry wall grab

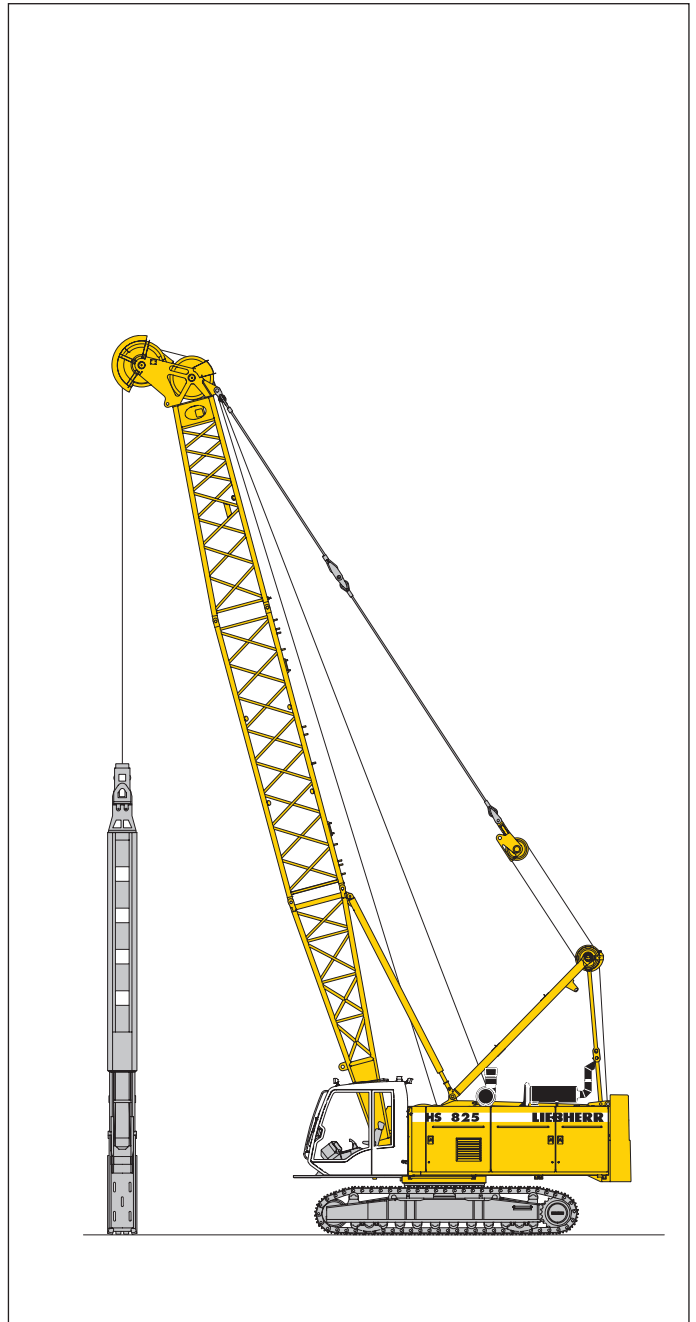
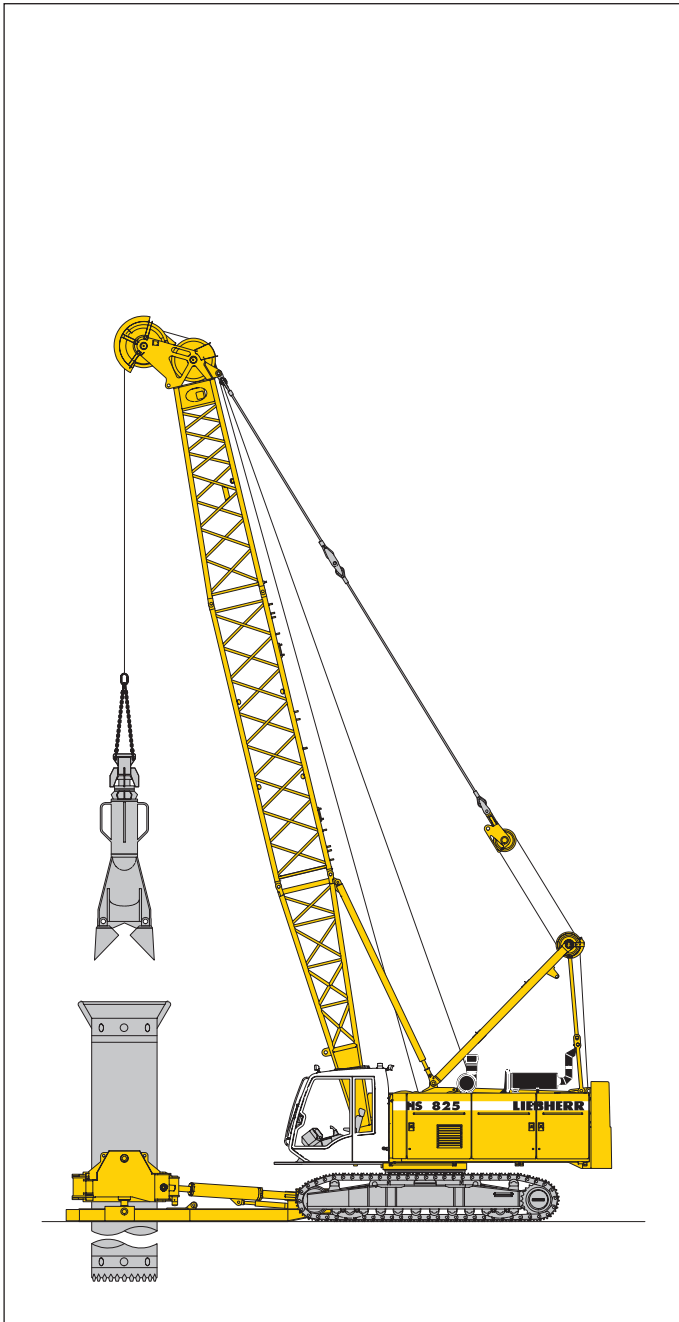

Casing oscillator

Winch options	2 x 160 kN
Line speed 1st layer	0–130 m/min
Drilling diameter	1200 mm
Maximum allowable weight in two rope operation	16 t

Slurry wall grab

Winch options	2 x 160 kN
Line speed 1st layer	0–130 m/min
Max. chisel weight	10 t
Maximum allowable weight in two rope operation	16 t

Standard main boom (No. 1310.17) 82° - 15°

12.7 t counterweight

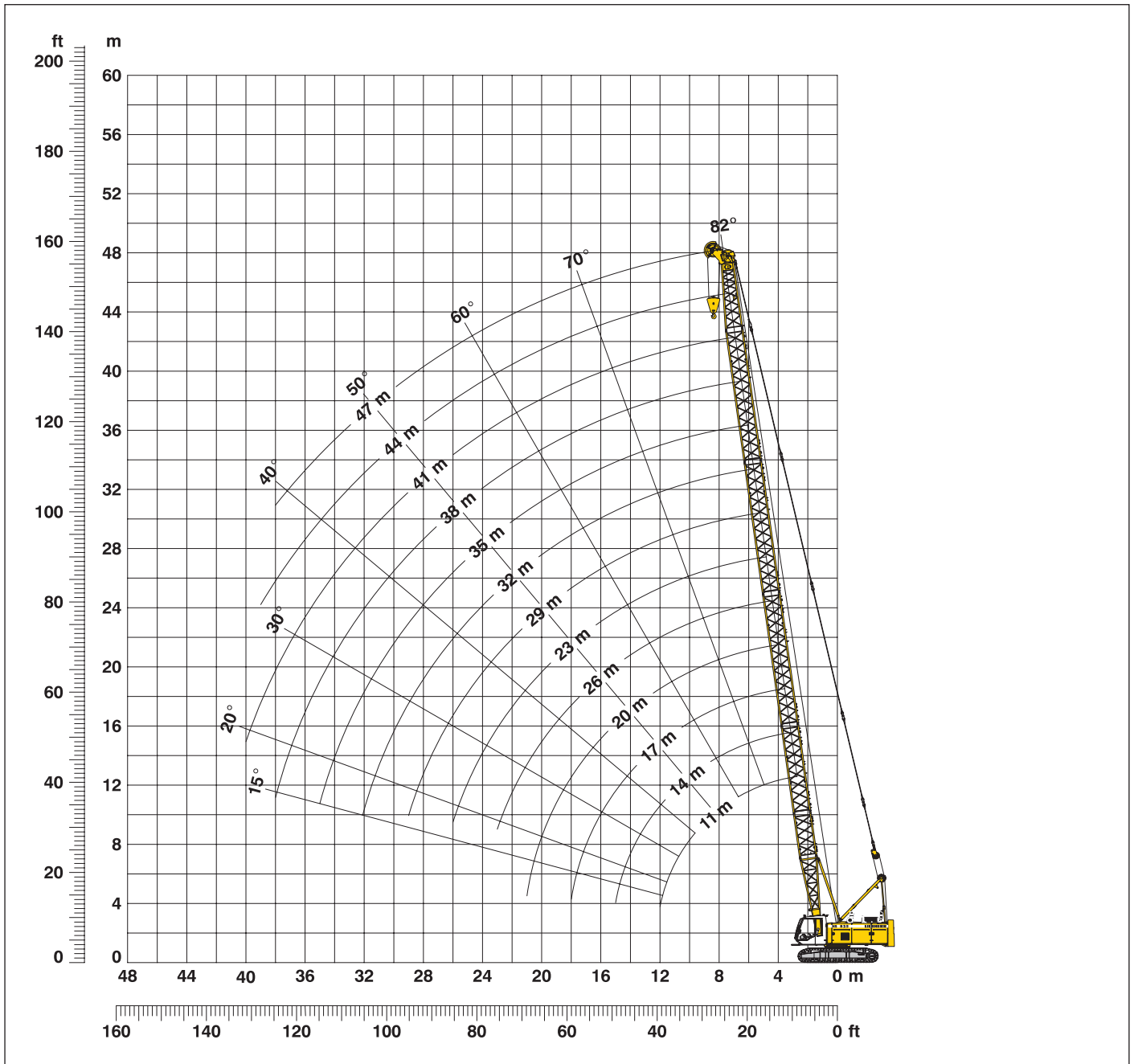

Standard main boom configuration

Configuration for boom lengths (11 m - 47 m)

	Length	Amount of boom extensions												
		1	1	1	1	1	1	1	1	1	1	1	1	1
Boom foot	5.5 m	1	1	1	1	1	1	1	1	1	1	1	1	1
Boom insert	3.0 m		1		1		1		1		1		1	
Boom insert	6.0 m			1	1			1	1			1	1	
Boom insert	12.0 m					1	1	1	1	2	2	2	2	3
Boom head	5.5 m	1	1	1	1	1	1	1	1	1	1	1	1	1
Boom length (m)		11	14	17	20	23	26	29	32	35	38	41	44	47

Lift chart for standard main boom (No. 1310.17)

12.7 t counterweight

Capacities in metric tons for boom lengths (11 m - 47 m) - with 160 kN winches

Radius	Boom length (m)													Radius
	11	14	17	20	23	26	29	32	35	38	41	44	47	
m	t	t	t	t	t	t	t	t	t	t	t	t	t	m
4	43.5	40.6												4
5	32.4	30.7	29.2	27.7	23.3									5
6	25.7	24.6	23.6	22.5	21.6	20.8	19.9							6
7	20.5	20.4	19.7	18.9	18.2	17.6	16.9	16.3	15.7	15.0				7
8	16.9	16.9	16.8	16.2	15.7	15.2	14.6	14.1	13.7	13.2	12.7	12.4		8
9	14.3	14.3	14.3	14.2	13.7	13.3	12.9	12.4	12.0	11.7	11.3	11.0	10.6	9
10	12.3	12.4	12.4	12.3	12.2	11.8	11.5	11.1	10.8	10.4	10.1	9.8	9.4	10
12	9.6	9.6	9.7	9.6	9.6	9.6	9.3	9.0	8.7	8.4	8.2	7.9	7.6	12
14		7.8	7.8	7.7	7.7	7.7	7.6	7.4	7.2	7.0	6.8	6.5	6.3	14
16			6.4	6.4	6.4	6.3	6.3	6.2	6.1	5.9	5.7	5.5	5.2	16
18			5.4	5.4	5.4	5.3	5.3	5.2	5.1	5.0	4.8	4.6	4.4	18
20				4.6	4.6	4.5	4.5	4.4	4.3	4.2	4.1	3.9	3.7	20
22					3.9	3.9	3.8	3.7	3.7	3.6	3.5	3.3	3.1	22
24						3.3	3.3	3.2	3.2	3.1	3.0	2.8	2.7	24
26							2.9	2.8	2.8	2.7	2.6	2.6	2.4	26
28								2.5	2.4	2.3	2.3	2.2	2.1	28
30									2.1	2.0	1.9	1.9	1.8	30
32									1.8	1.7	1.7	1.6	1.5	32
34										1.5	1.4	1.3	1.2	34
36											1.2	1.1	1.0	36

Above lift chart is for reference only. For actual lift duty please refer to lift chart in operator's cab or manual.

